

BWM 30 Ton Log Splitter

(with hydraulic lifting table)

User's Manual

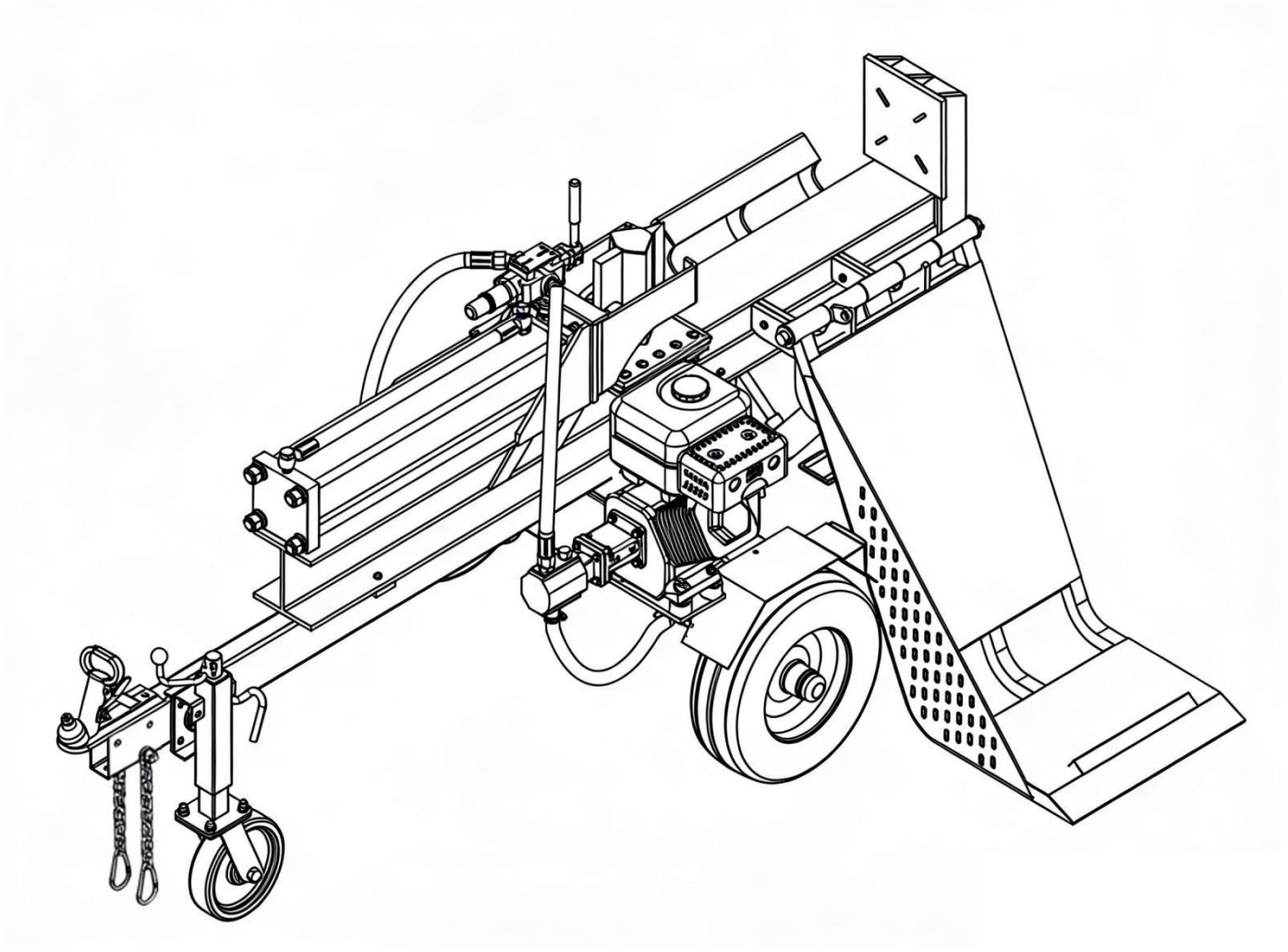

BWM LSD30 Deluxe Series

Please read through this owner's manual carefully before using the product, to ensure the safety of yourself and others.

*Due to continuing improvements, actual product may differ slightly from the product described herein.

Index

1. General Warnings and Rules.....	3
2. Hazard Signal Definitions	4
3. Parts Component	5
3. Controls and Features Identification	6
4. Assembly Instructions	8
5. Operating Instructions	16
6. Maintenance and Storage	20
7. Troubleshooting	21
8. Specifications.....	22
9. Warranty	23
10. Illustrated Parts List.....	24



GENERAL WARNINGS



READ and UNDERSTAND this manual completely before using 30 Ton Log Splitter.

Operator must read and understand all safety and warning information, operating instructions, maintenance and storage instructions before operating this equipment. Failure to properly operate and maintain the log splitter could result in serious injury to the operator or bystanders.

Operation Warnings

- Do not at any time carry passengers, sit or stand on the log splitter.
- Do not allow children to play on, stand upon or climb on the log splitter.
- Always inspect the log splitter before using to assure it is in good working condition.
- Replace or repair damaged or worn parts immediately.
- Always check and tighten hardware and assembled parts before operation.
- Do not exceed equipment maximum load capacity of 30 tons.
- Avoid large holes and ditches when towing the equipment.
- Always operate the log splitter on clear and level ground.
- Do not operate the log splitter at night, only during daylight hours.
- Always tow at reduce speed in rough terrain, along creeks, ditches and on hillsides.
- To avoid personal injury and/or equipment damage **DO NOT EXCEED 72 KM/H.**
- Always refer to the vehicle owner's manual for proper towing.
- Always secure and lock the log splitter to the vehicle hitch before towing.

Crush and Cut Hazards

- Always keep hands and feet clear from moving parts while operating the equipment.
- Always clear and keep work area clean and free of debris when operating.
- Always wear safety gear, eye protection, gloves and work boots when operating the log splitter.







WARNING

The warnings, cautions, and instructions outlined in this instruction manual cannot cover all possible conditions or situations that may occur. It must be understood by the operator that common sense and caution are factors which cannot be built into this product and must be supplied by the operator.

Assembly Is Required

This product requires assembly before use. See "Assembly" section for instructions. Because of the weight and/or size of the log splitter, it is recommended that another adult be present to assist with the assembly. **INSPECT ALL COMPONENTS** closely upon receipt to make sure no components are missing or damaged.

Hazard Signal Word Definitions

	<p>This is the safety alert symbol. It is used to alert you to potential personal injury hazards. Obey all safety messages that follow this symbol to avoid possible injury or death.</p>
	<p>DANGER indicates an imminently hazardous situation which, if not avoided, will result in death or serious injury.</p>
	<p>WARNING indicates a potentially hazardous situation which, if not avoided, could result in death or serious injury.</p>
	<p>CAUTION indicates a potentially hazardous situation which, if not avoided, may result in minor or moderate injury.</p>
	<p>CAUTION used without the safety alert symbol indicates a potentially hazardous situation which, if not avoided, may result in property damage.</p>

ABOUT YOUR 30 TON LOG SPLITTER

This hydraulic log splitter has a heavy-duty steel construction and 30 tons of ram force. When there's work to be done, you need outdoor power equipment you can rely on, this log splitter will get the job done fast. It is designed to work in the horizontal position. It is easy to tow, easy to use and maintain. Never exceed the rated capacity of 30 tons when operating the log splitter.

Technical specifications on the log splitter are provided in the "Specifications" section of this manual.

Parts Component

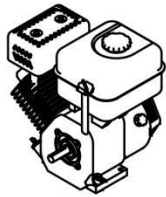

Engine

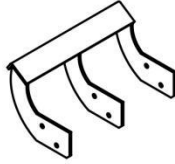

Log Cradle

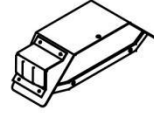

Left Fender

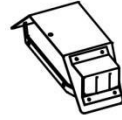

Right Fender

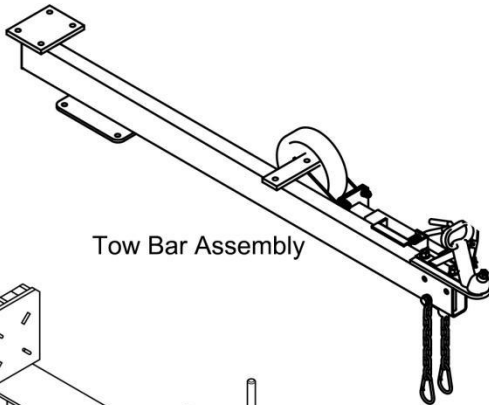

Tow Bar Assembly



Oil Drum

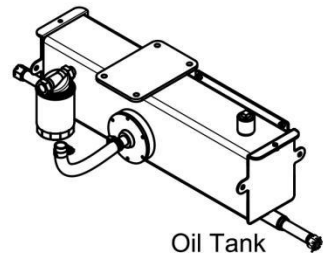

Oil Tank

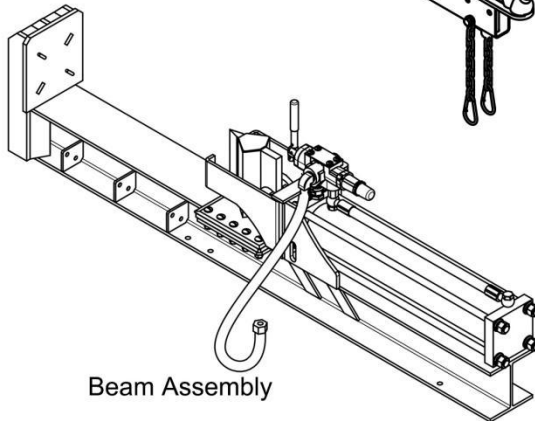

Beam Assembly

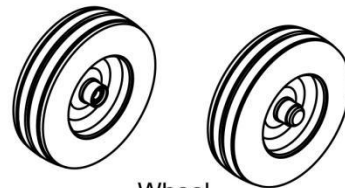

Wheel

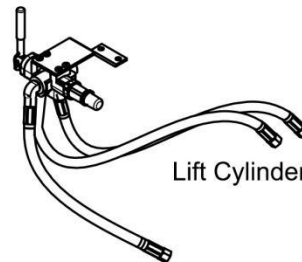

Lift Cylinder Control Valve

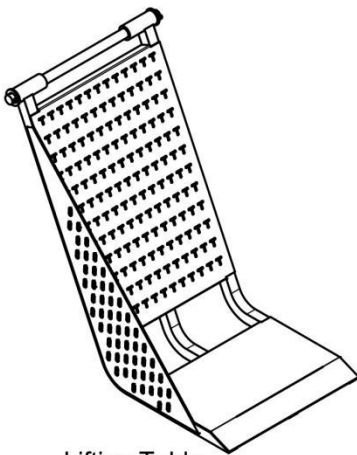

Lifting Table

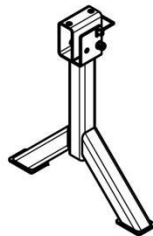

Support Frame



Lift Cylinder Assembly

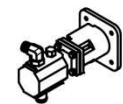

Gear Pump

Controls and Features Identification

Read this owner's manual before operating the equipment. Familiarize yourself with the location and function of the controls and features. Save this manual for future reference.

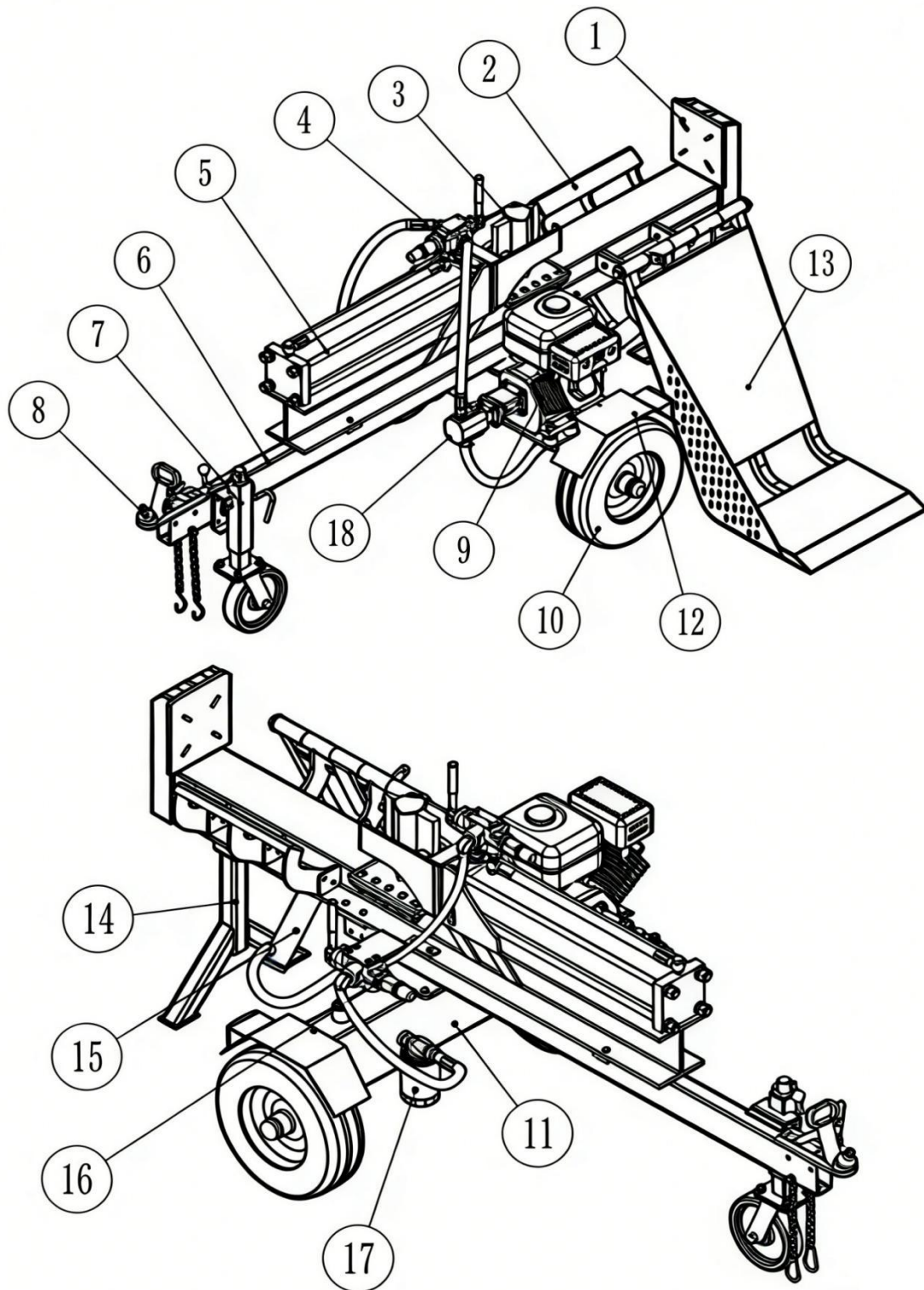

1. **Beam**
2. **Log Cradle-** Keeps the log on the beam without operator assistance.
3. **8” Wedge** – Features wedge wings and tapered ends making splitting easier.
4. **Control Valve** – Controls the forward and backward movement of splitting wedge
5. **Hydraulic Cylinder-** 4 1/2” bore and 23” stroke.
6. **Tow Bar**
7. **Jockey Wheel – 8”**
8. **50mm Coupler** – Attaches the log splitter to the 50mm hitch ball
9. **Engine** –Honda GX200 or Briggs 6.5HP
10. **Tyres** – Maximum rated towing speed is 72 KM/H
11. **Oil Tank** – Capacity 14L
12. **Fender**
13. **Lifting Table** – used to lift the log
14. **Rear Support Leg** – The leg supports the log splitter steadily while operating
15. **Hydraulic Table Lift Cylinder** – to lift and lower the hydraulic table
16. **Hydraulic Table Control Valve**
17. **External Filter** – Filters the hydraulic oil.
18. **Gear Pump** – Pumps the hydraulic oil through the system.

 **WARNING**



Engine Shipped Without Oil.

Before starting engine, fill with 600ml of Briggs SAE30 engine oil or Honda 10W30 engine oil, depending on your model. See engine manual for engine oil capacity.

Hydraulic Oil Tank is Shipped Without Oil.

Add 10L of AW32/AW46 hydraulic oil before the first use. When topping up oil verify the oil level using the Oil filter/Dip Stick on the top of hydraulic oil tank. .

Inspect all Log Splitter Components.

If you have damaged components: Contact the freight company that delivered the log splitter and file a claim.

Read and follow all instructions for assembly and operation. Failure to properly assemble this equipment could result in serious injury to the user or bystanders, or cause equipment damage.

Assembly Instructions

30 TON LOG SPLITTER ASSEMBLY

Set the shipping crate on a solid flat surface and carefully remove the lid. Use two people and take all parts out of the shipping crate and inspect the components to ensure there are no missing pieces before starting to assemble the log splitter follow steps 1 through 8.

TOOLS REQUIRED

- Rubber or Wooden Hammer
- 13mm, 16mm, 17mm, 18mm, 19mm, 24mm, 27mm Wrenches
- Large Adjustable Wrench
- Phillips or Standard Screwdriver
- Pliers

STEP 1: Wheel Assembly

1. Attach the wheels (#76) to the oil tank (#52) using flat washer $\text{Ø}20$ (#77), hex slotted nut (#78) and cotter pin $\text{Ø}4 \times 40$ (#79). Install the axle cap (#80) on the end.

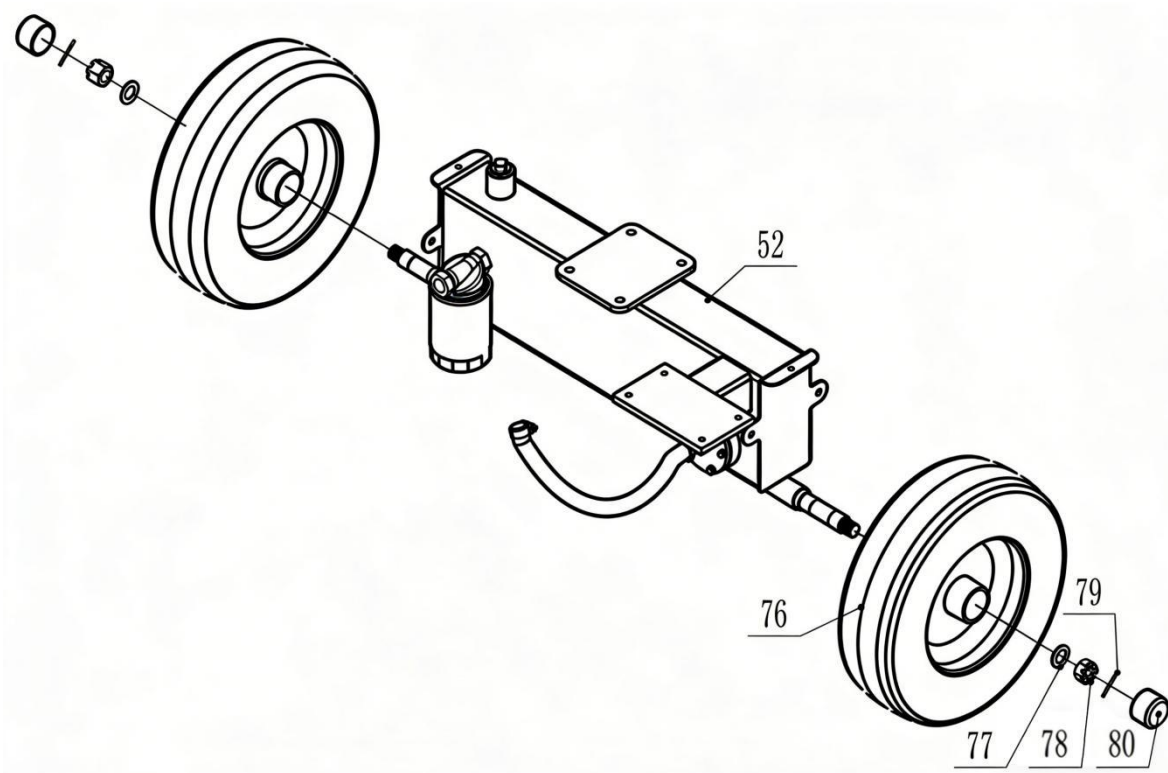

STEP 2: Attach Tow Bar to the Oil Tank

1. Attach the tow bar (#50) to the oil tank (#52) using hex bolt M12x35 (#51), flat washer \varnothing 12 (#18) and nylon lock nut M12 (#21).

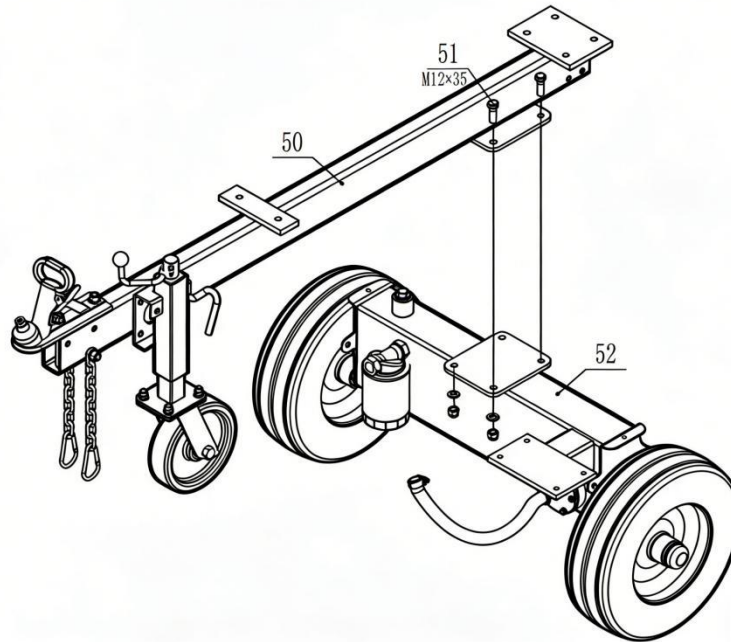

STEP 3: Attach The Wheel Fenders

1. Attach the fender (#49#84) to the wheel using hex bolt M10x20 (#82), spring washer \varnothing 10 (#83), flat washer \varnothing 10 (#3), and hex bolt M10x25 (#81), flat washer \varnothing 10 (#3), nylon lock nut M10 (#4).

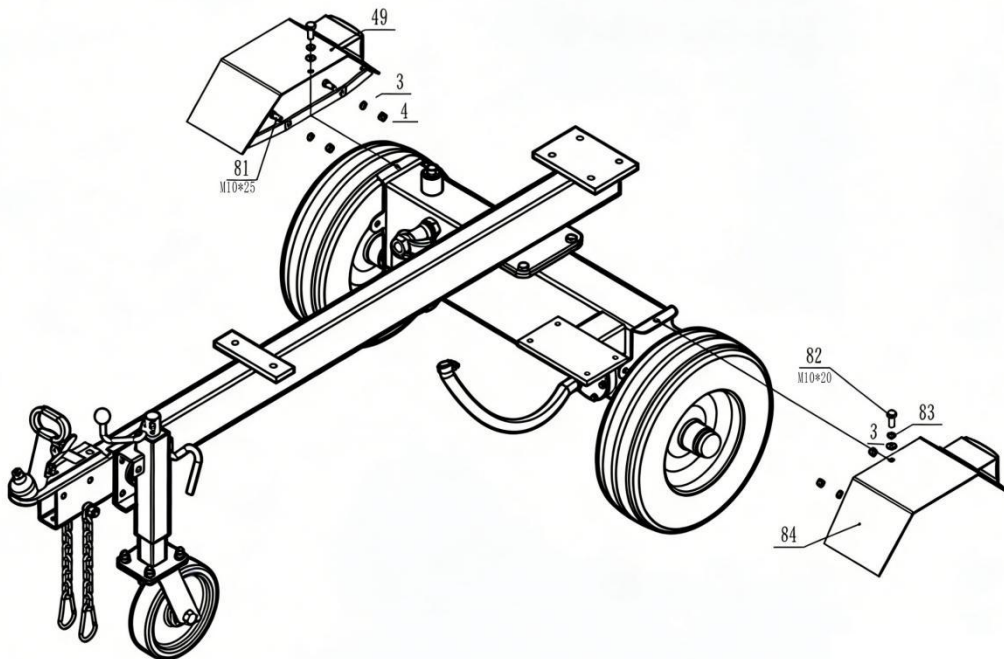

STEP 4: Assemble Gear Pump (Assembled in Australia Factory)

1. Take down the flat key (#71) from the engine shaft, put the engine bushing (#72) to the engine shaft, insert the flat key (#71) to the engine shaft again, then assemble the engine coupler (#70) to the engine shaft.
2. Assemble the gear pump assembly (#62) to the engine by using hex bolt M8x25 (#73), spring washer Ø8 (#74) and flat washer Ø8 (#64).

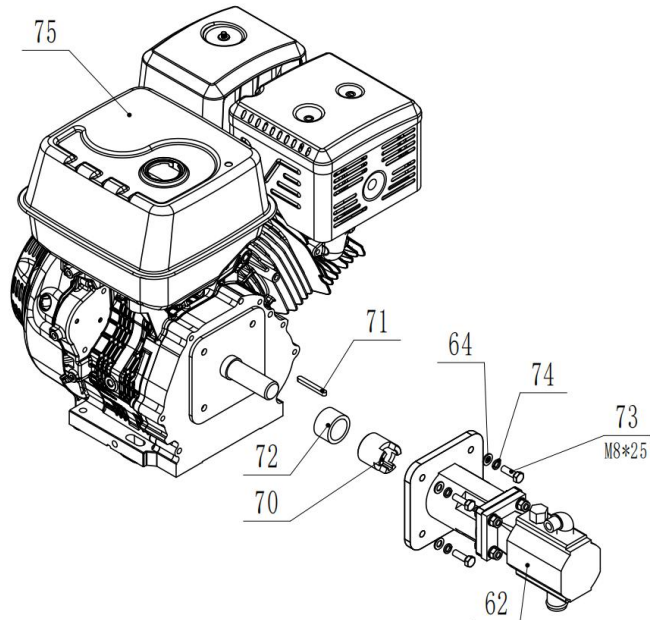

STEP 5: Attach the Engine

1. Attach the engine to the engine mounting plate using hex bolt M8x70 (#91), flat washer Ø8 (#64) and nylon lock nut M8 (#63).
2. **Note:** Put polyurethane block (#61) and big flat washer Ø8 in between engine and mounting plate.

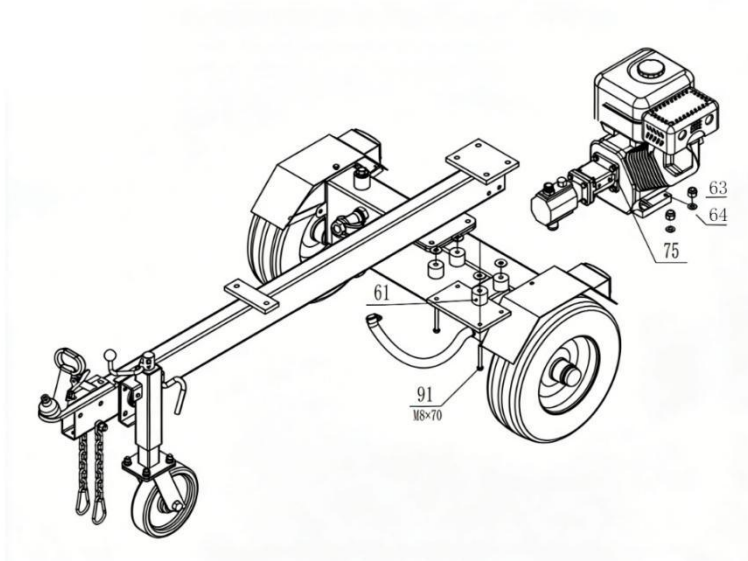

NOTE: If you insert the bolts from the bottom plate, secure them using duct tape to hold them in place while lining up the engine holes with the bolts. Remove the tape from the bottom of the mounting plate once tightened.

STEP 6: Attach the Beam Assembly to the Tow Bar

1. Attach beam assembly to the oil tank using hex bolt M12x45 (#43), flat washer Ø12 (#18) and nylon lock nut M12 (#21).

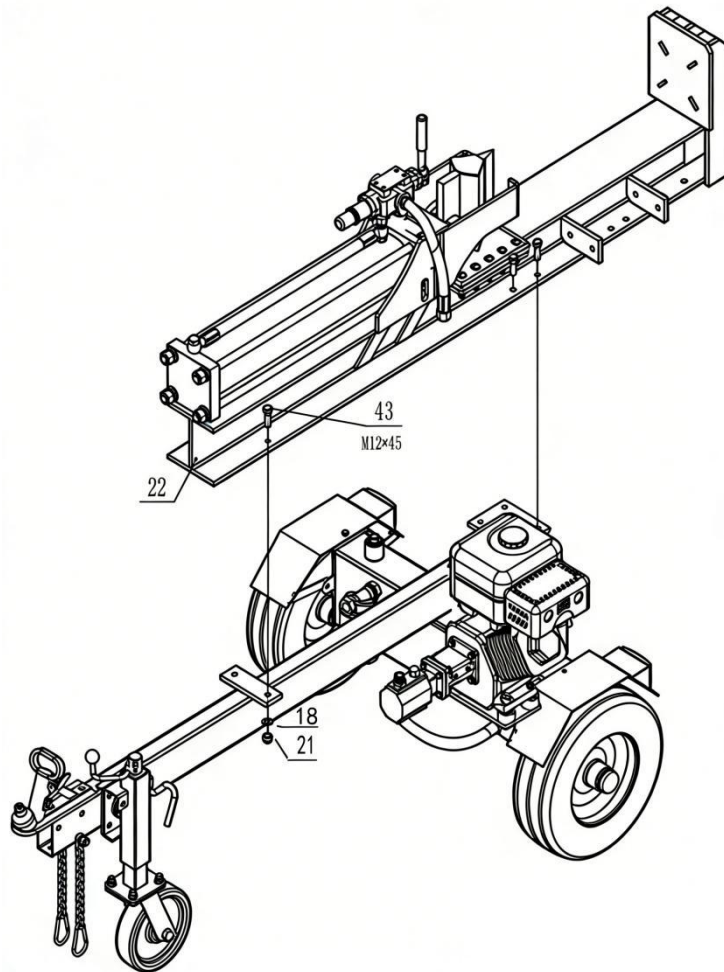

STEP 7: Attach the Log Cradle

1. Attach the log cradle (#36) to the beam using hex bolt M10x30 (#1), flat washer Ø10 (#3) and nylon lock nut M10 (#4).

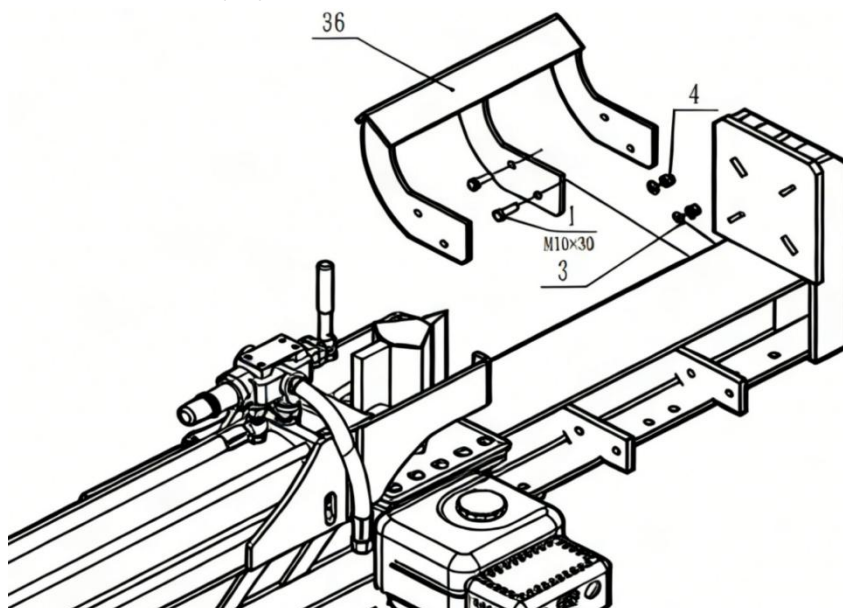

STEP 8: Attach the Support Leg and Connecting Frame

1. Attach the connecting frame (#44) to the beam by using hex bolt M12x45 (#43).
2. Attach the support leg (#47) to the connecting frame (#44) by using hex bolt M10x80 (#45) flat washer $\varnothing 10$ (#3) , nylon lock nut M10(#4) and fixed Pin (#46).
3. Attach the connecting frame (#86-11) to the beam using hex bolt M12x45 (#43), flat washer $\varnothing 12$ (#18) and nylon lock nut M12 (#21).

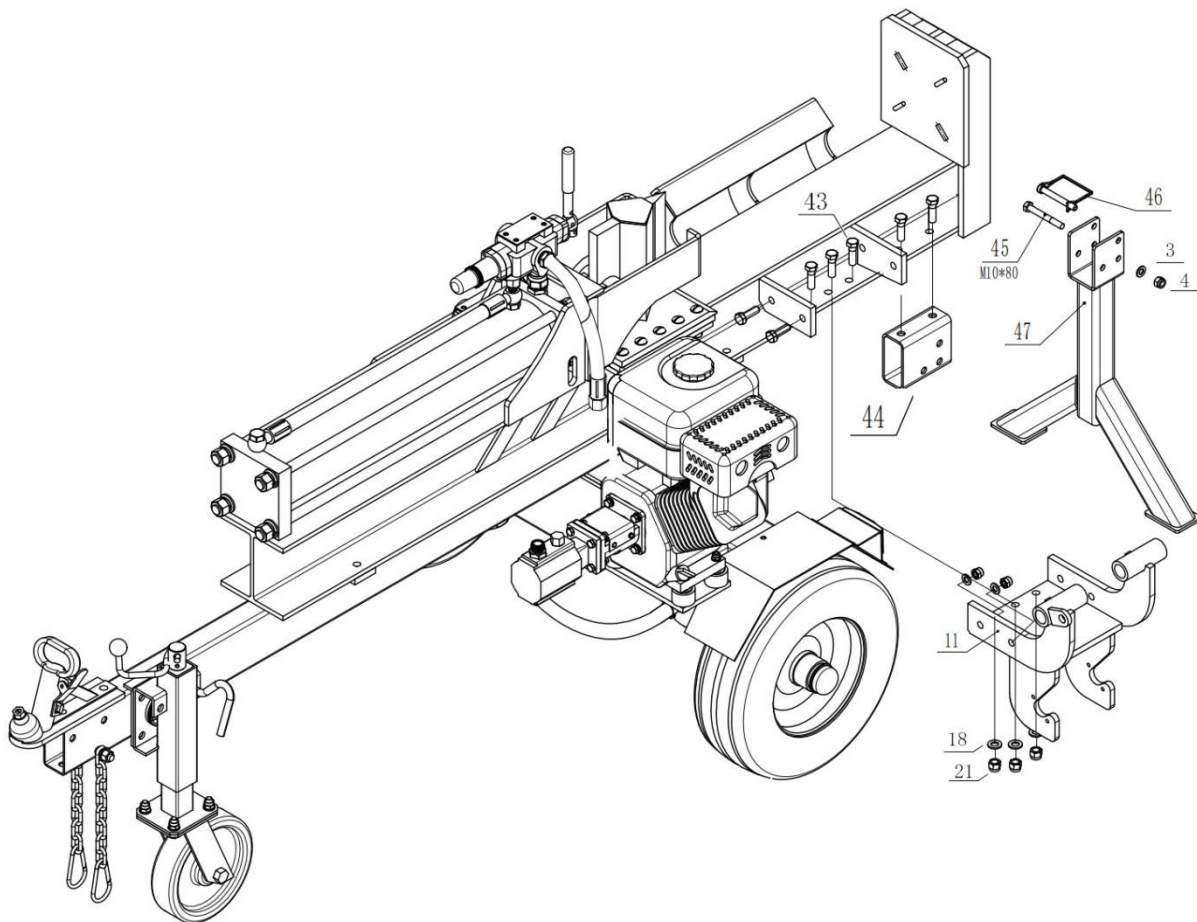

STEP 9: Attach the Lifting Table and Lift Cylinder

1. Attach the lifting table (#86-17) and lift arm (#86-18) to the connecting frame (#86-11) using hinge pin (#86-25), washer (#86-8), screw M6x35 (#86-10) and nylon lock nut M6 (#86-9).
2. Attach the lift cylinder (#86-22) to the lift arm (#86-18) using nylon lock nut M12 (#86-21), washer (#86-20) and hex bolt M12x70 (#86-19).
3. Attach the lift cylinder (#86-22) to the connecting frame (#86-11) using safety piece, flat washer $\varnothing 8$ (#86-14), spring washer $\varnothing 8$ (#86-13) and hex bolt M8x20 (#86-12).
4. Insert safety pin (#86-16) to the lifting table (#86-17), tighten with R pin (#86-15).

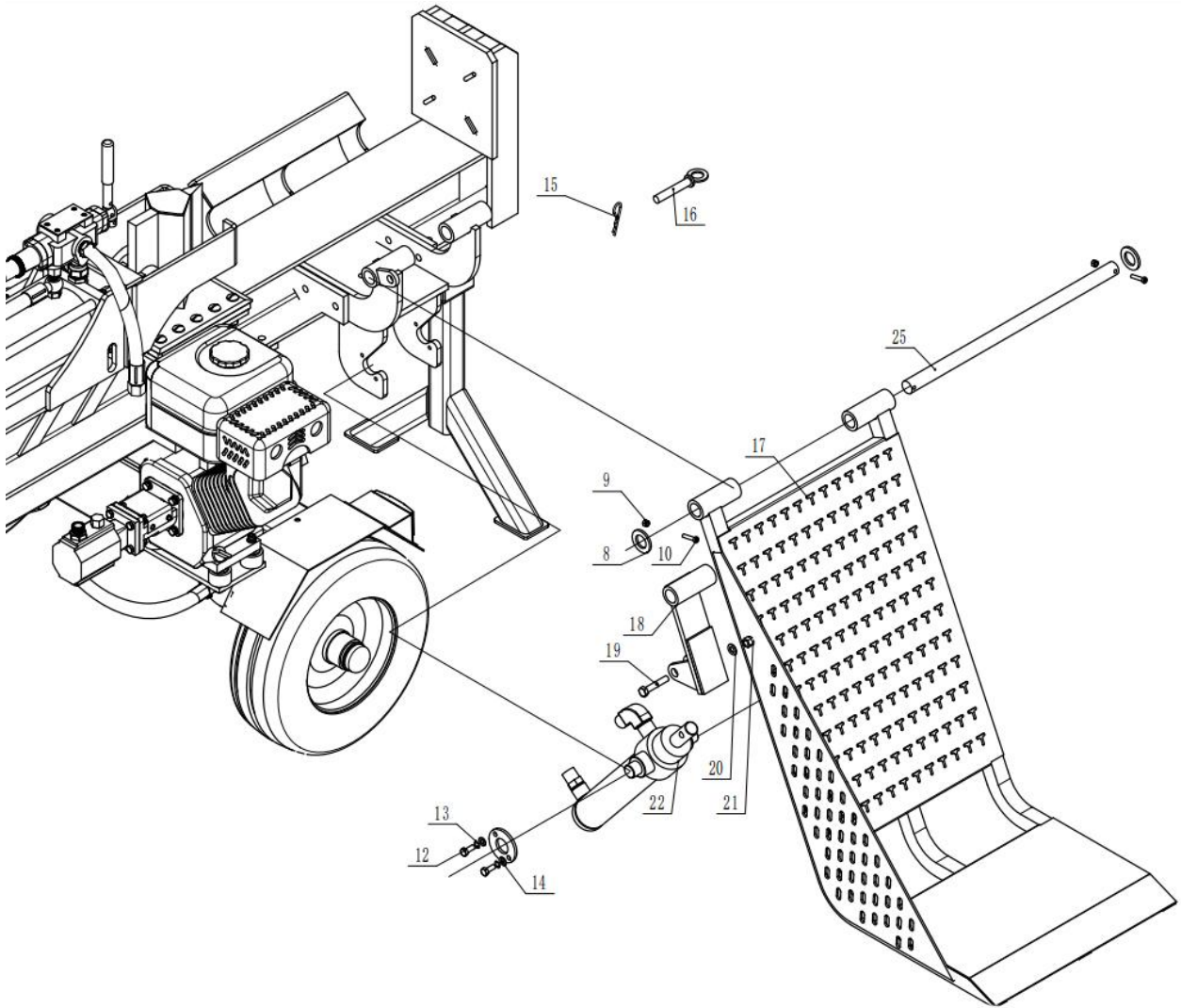

STEP 10: Attach the Lift Cylinder Control Valve and Hydraulic Hose

1. Attach the lift cylinder control valve to the beam using hex bolt M12x45 (#43), flat washer Ø12 (#18), hex lock nut M12 (#21).
2. Connect the hydraulic hose (valve-gear pump) (#93) to the gear pump outlet connector C2.
3. Connect the hydraulic hose (valve-oil tank) to the outside oil filter connector E.
4. Connect the hydraulic hose (valve-valve) (#94) to the control valve connector. (to B2)
5. Connect the hydraulic hose to the lift cylinder connector F.
6. Connect another hydraulic hose to the another lift cylinder connector G.
7. Attach the oil pipe (#95) to the gear pump outlet connector A2 and oil tank flange, tighten with clamp.

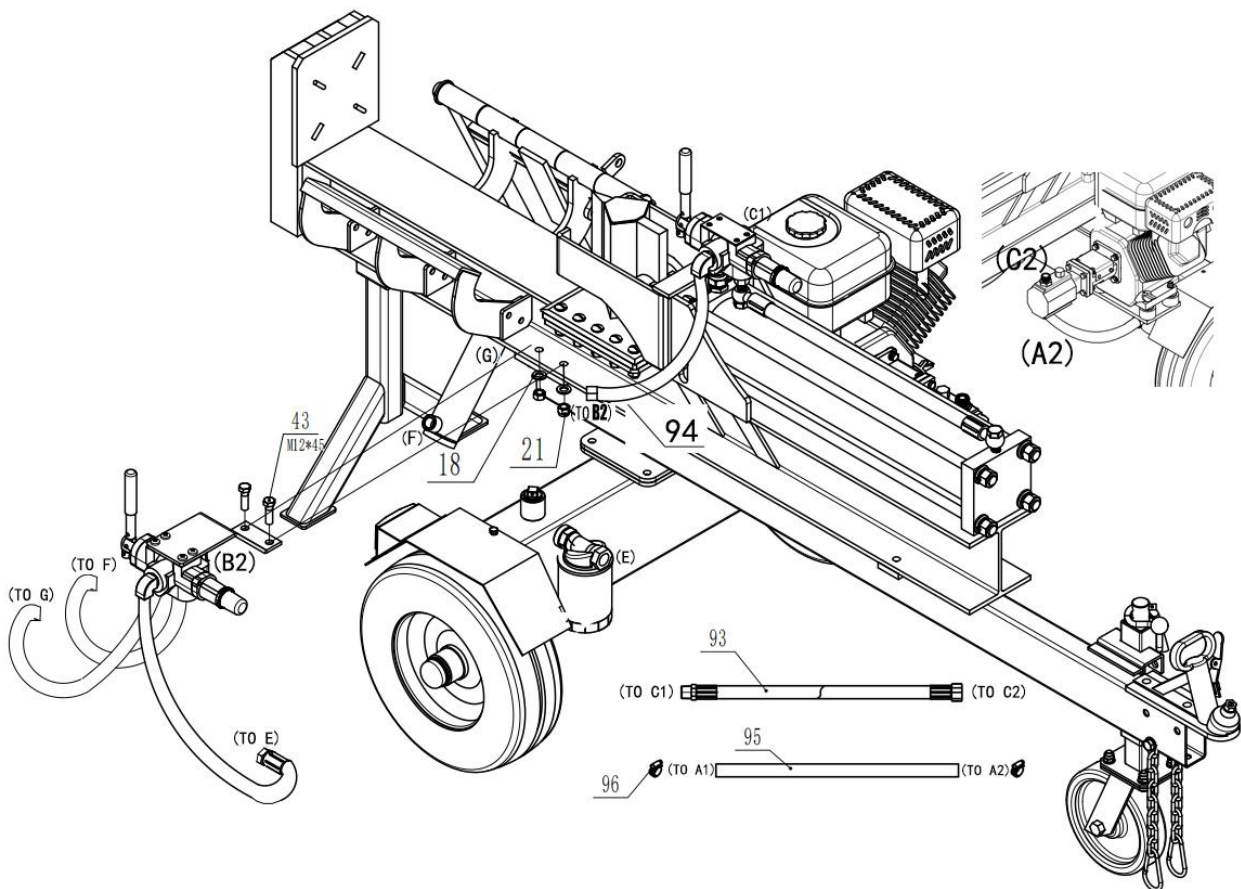

STEP 11: Add Engine Oil

1. Make sure the log splitter is on a level surface.
2. Unscrew the oil fill cap/dipstick to add oil.
3. Add 600ml of engine oil (SAE30 or 10W30, depending on your model). Refer to owner's engine manual for more details. Replace the oil fill cap/dipstick.
4. Check engine oil level each use and add as needed.

NOTE: During the break-in period check the engine oil level more often.

CAUTION

DO NOT attempt to crank or start the engine before it has been properly filled with the recommended type and amount of oil. Damage to the log splitter as a result of failure to follow these instructions will void your warranty.

STEP 12: Add Fuel to the Engine

1. Use only clean, fresh, regular unleaded 91 fuel.
2. DO NOT mix oil with fuel.
3. Remove the fuel cap and slowly add fuel to the tank. DO NOT overfill, allow approximately ¼ inch of space for fuel expansion.
4. Screw on the fuel cap and wipe away any spilled fuel.

DANGER

Log splitter engine exhaust contains carbon monoxide, a colourless, odourless, poison gas. Breathing carbon monoxide will cause nausea, dizziness, fainting or death. If you start to feel dizzy or weak, get to fresh air immediately.

Operate log splitter outdoors only in a well ventilated area.

DO NOT operate the log splitter inside any building, enclosure or compartment.

DO NOT allow exhaust fumes to enter a confined area through windows, doors, vents or other openings.

DANGER: CARBON MONOXIDE, using a log splitter indoors **CAN KILL YOU IN MINUTES.**

CAUTION

Fuel and fuel vapors are highly flammable and extremely explosive.

Fire or explosion can cause severe burns or death.

Unintentional startup can result in entanglement, traumatic amputation or laceration.

Only use regular unleaded 91 fuel.

DO NOT mix oil and petrol together.

Fill tank approximately ¼" below the top of the tank to allow for fuel expansion.

DO NOT fill fuel tank indoors or when the engine is running or hot.

DO NOT light cigarettes or smoke when filling the fuel tank.

STEP 13: Add Hydraulic Oil

1. The log splitter needs to be on a flat, level surface before adding the hydraulic oil.
2. Remove the oil cap from the hydraulic oil tank.
3. Add 14 liters of AW32/AW46 hydraulic oil.
4. Check the hydraulic oil level.
5. Start engine and use the control lever to extend and retract wedge several times to remove air from the lines.
6. With the wedge retracted, check hydraulic oil level again and fill if necessary.

WARNING

DO NOT remove the hydraulic oil fill cap when the engine is running or hot. Hot oil can escape causing severe burns. Always allow the log splitter to cool completely before removing the hydraulic oil cap.

High fluid pressure and temperatures are created in the hydraulic log splitters. Hydraulic fluid will escape through a pin-size hole opening and can puncture skin and cause severe blood poisoning.

Inspect hydraulic system regularly for possible leaks. **Never check for leaks with your hand while the system is pressurized. Seek medical attention immediately if injured by escaping fluid.**

Make sure all fittings are tight and secure before applying pressure. Relieve system pressure before servicing.

Make sure the hydraulic hoses do not touch any hot surfaces or cutting areas.

Hoses need to be positioned where they are clear from the engine and cutting wedge. To avoid serious bodily injury always inspect the hoses before operating the log splitter.

Operating Instructions

! WARNING

Before operating or using the log splitter, review the instructions below and all safety information. Failure to follow these instructions may result in property damage or injury to the operator or bystanders

! WARNING

ALWAYS use the log splitter for its intended use.
ONLY use the log splitter to split wood logs, length wise with the grain.
NEVER modify, alter or change the log splitter in anyway, modifications will void the warranty.
NEVER attach a rope, cable or other device to the control lever on the log splitter.
ONLY operate the log splitter in daylight.
NEVER leave the log splitter unattended while the engine is running.
DO NOT change the splitting position with the engine running. Contact with the muffler can cause serious burns.
ALWAYS make sure the beam is in the locked position.
DO NOT let the beam drop as it could crush fingers or cause damage to the log splitter.
NEVER operate or let anyone else operate, the log splitter while under the influence of alcohol, drugs, or medication.

USING YOUR LOG SPLITTER

1. DO NOT at any time carry passengers, sit or stand on the log splitter.
2. Check the hydraulic oil level and visually inspect all hoses and attachments for problems.
3. Inspect the engine and make sure the engine oil level is correct.
4. Before towing the log splitter the tyres need to be fully inflated.

! TYRE WARNING

DO NOT over inflate tyres. Serious injury can result if tyres explode.
DO NOT tow the log splitter if the tyres are worn or will not hold air.
DO NOT exceed the maximum 72 KM/H towing speed.

5. Refer to the vehicle owner's manual for proper safety and towing instructions.

! TOWING WARNING

Serious injury or death can occur if towing safety rules are not followed.
Always use safety chains, secure and lock the log splitter to the vehicle hitch before moving.
Drive safely. Be aware of the added length of the log splitter.
Never exceed the maximum travel speed of 72 KM/H.
Never ride or transport cargo on the log splitter.
Turn off the vehicle before leaving the log splitter unattended.
Block the log splitter wheels to prevent unintended movement.

6. The log splitter must have at least 2 meters of clearance from combustible material. It needs to be on a dry and level surface with good footing. Do not work on mud, ice, brush or snow.
When using the log splitter the work zone must be maintained at all times.

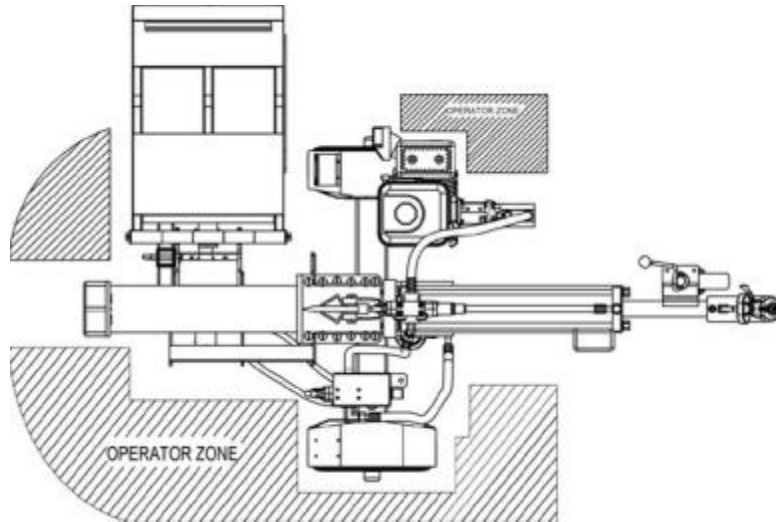

NOTE: Serious accidents can happen when other people are allowed inside the work zone. Keep everyone else outside the work zone while operating the control lever.

7. Always wear safety gear, eye protection, gloves and work boots when operating the log splitter.
8. Start the engine and make sure the log splitter is on level ground before operating.

NOTE: The hydraulic oil needs to be above -12C° before starting the engine. Cold hydraulic oil can damage the hydraulic pump. If outdoor air temperature is below 0C° allow the log splitter to warm up by extending and returning the wedge several times before splitting wood.

9. Put the support leg or jockey wheel in the down position to prevent the log splitter from moving during operation and block both tyres.
10. Set the log splitter in horizontal position.

11. Load a log onto the beam against the endplate (Max Log Length-24”).

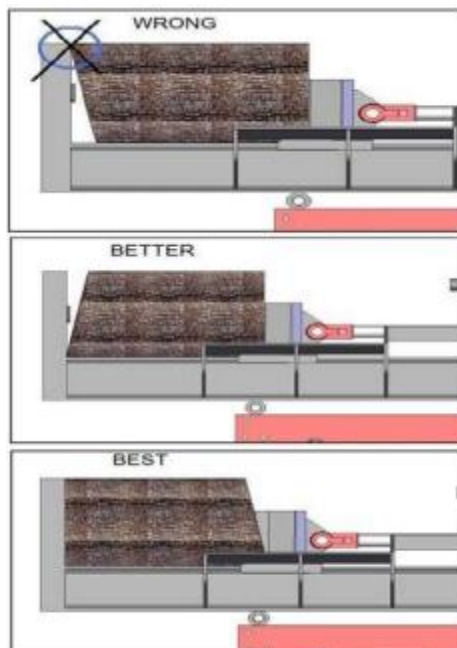

12. Make sure hands are clear from the wedge and crush hazard areas.

CRUSH WARNING

Wedge can cut through skin and break bones. Keep both hands away from wedge and beam slide.

Serious accidents can happen when other people are allowed inside the work zone. Keep everyone else out of the work zone while operating control lever.

DO NOT wear loose clothing. It can get tangled in moving parts of log splitter.

Only use the log splitter in daylight so you can see what you are doing.

13. Push control lever FORWARD by one hand to split the log.

14. Push control lever BACKWARD by one hand to return wedge to its original position.

CAUTION

If a log gets stuck, embedded or will not split completely, push the control lever in the reverse direction and allow the splitter to strip the log from the wedge.

If the log still remains stuck, embedded or will not split, turn the machine off and use a sledge hammer and crow bar to remove the log.

ALWAYS keep hands clear of the log and wedge while it is retracting.

15. Always keep work zone clean and free of split wood and debris.

Operating Instructions

HORIZONTAL USING ONLY

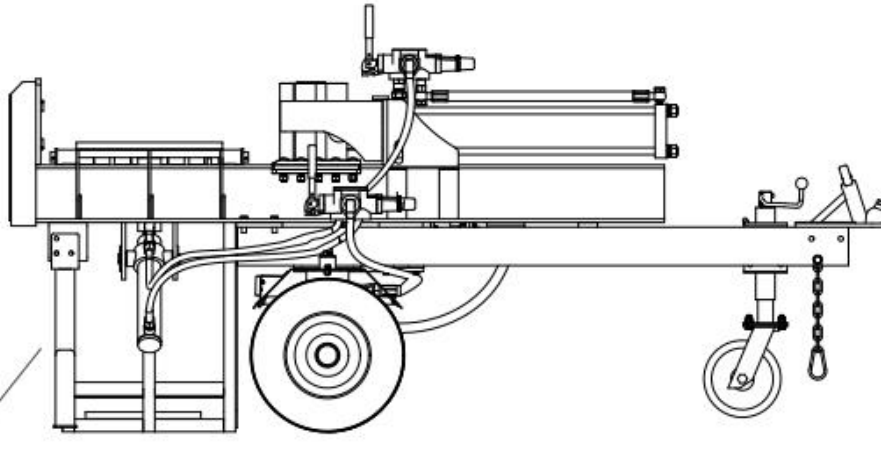

Rotate rear leg down
and slide the lock pin

FOR VEHICLE TOWING

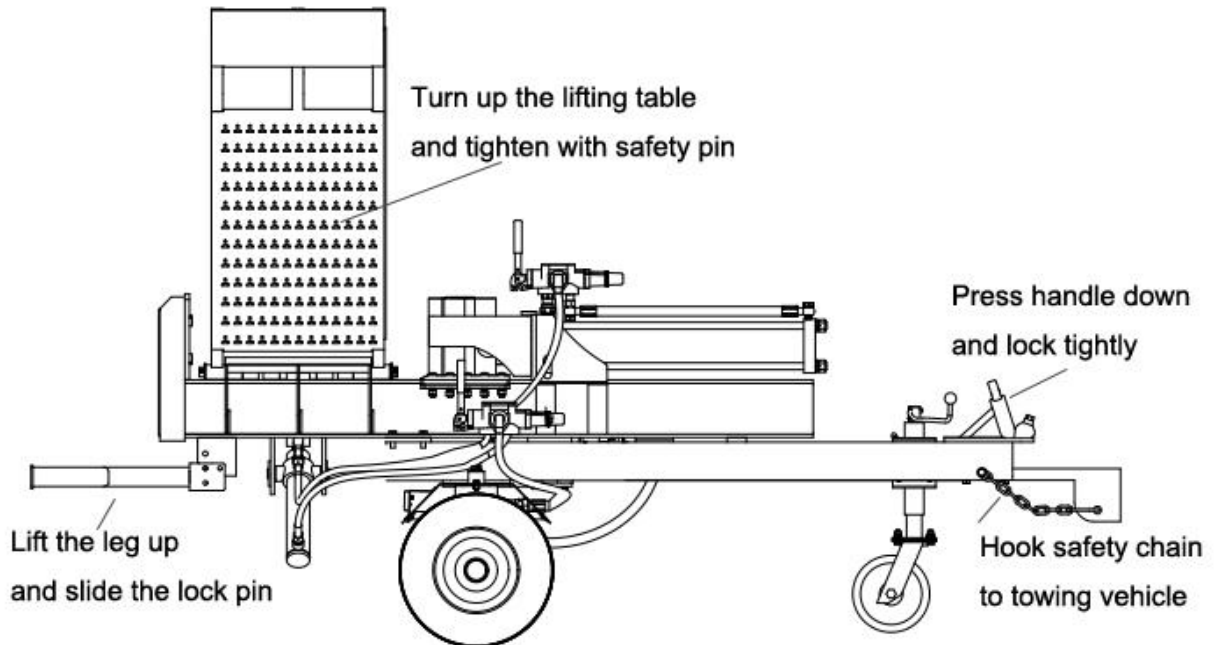

Maintenance and Storage

CAUTION

Improper maintenance and storage of the log splitter may void your warranty.

MAINTENANCE

- Before performing any maintenance, the log splitter must be placed in maintenance mode. Turn off the engine and move the control lever forward and backwards to relieve the hydraulic pressure.
- After performing any maintenance, make sure all guards, shields and safety features are put back in place before operating the log splitter.
- Before operating make sure the tyres have the RECOMMENDED TYRE PRESSURE.
- Regularly grease axle and wheel bearing area or when needed.
- Periodically check all fasteners and hoses for tightness and leaks.
- Annually clean and lightly lubricate all moving parts or when needed.
- Use a glossy enamel spray paint to touch up scratched or worn painted metal surfaces.
- Never exceed load capacity rating of 30 tons it will damage the log splitter.

What	When	How
Hoses	Each Use	Inspect hoses for exposed wire mesh and leaks. Replace all worn or damaged hoses before starting the engine.
Hydraulic Fittings	Each Use	Inspect fittings for cracks and leaks. Replace all damaged fittings before starting the engine.
Nuts and Bolts	Each Use	Check for loose bolts, tighten before operating.
Beam	Each Use	Apply grease to beam surface.
Moving Parts	Each Use	Clear debris from log splitter.

Refer to the Engine Owner's Manual for engine maintenance.

IMPORTANT:

If a part needs replacement, only use parts that meet the manufacturer's specifications. Replacement parts that do not meet specifications may result in a safety hazard or poor operations.

STORAGE

- Before storing make sure the log splitter is clean and dry for years of trouble-free service.
- Lightly lubricate all log splitter surfaces and moving parts to prevent rust.
- Store indoors or protected area during severe weather and winter months.

Troubleshooting

Problem	
Cylinder rod will not move	SOLUTION: A,D,E,H,J
Slow cylinder rod speed when extending or retracting	SOLUTION: A,B,C,H,I,K,L
Wood will not split or splits extremely slowly	SOLUTION: A,B,C,F,I,K
Engine bogs down during splitting	SOLUTION: G,L
Engine stalls under low load condition	SOLUTION: D,E,L,M
Engine starts problem	SOLUTION: N
Cause	Solution
A -Insufficient oil to pump	Check oil level in reservoir
B -Air in oil	Check oil level in reservoir
C -Excessive pump inlet vacuum	Check pump inlet hose for blockage or kinks
D -Blocked hydraulic lines	Flush and clean the splitter hydraulic system
E -Blocked control valve	Flush and clean the splitter hydraulic system
F -Low control valve setting	Adjust control valve with a pressure gauge
G -High control valve setting	Adjust control valve with a pressure gauge
H -Damaged control valve	Return control valve for authorized repair
I -Internal control valve leak	Return control valve for authorized repair
J -Internal cylinder leak	Return cylinder for authorized repair
K -Internally damaged cylinder	Return cylinder for authorized repair
L -Engine Control out of adjustment	Adjust idle control nuts
M -Engine is loaded during idle down mode	Use shorter log length (24" or less) to allow engine to speed up before contact.
N -Engine operation	Refer to the Engine Owner's Manual

Specifications

Ram Force	30 Ton
Cycle Time	12 Sec
Wedge Size.....	8" Hardened Steel
Hydraulic Tank Capacity.....	14L
Max. Log Length	24" (600mm)
Gear Pump.....	2-Stage
Hydraulic Oil.....	AW32/AW46 Hydraulic Oil
Hydraulic Cylinder	4 1/2" x 23"(115mm x 575mm)
Max. Flow.....	14 GPM
Wheel Size	16" / 4.80 x 8
Hitch Type	2" Ball Coupler
Max. Towing Speed.....	72 KM/H
Engine.....	Honda GX200 Or Briggs 6.5HP

NOTE: For Engine Details Refer to the Engine Owner's Manual.

Warranty

Limited Warranty

The warranty period for the log splitter is 3 years (Domestic use) and 1 year (commercial use) from the purchase date. The engine has a 3 year warranty. The warranty will not apply to any unit which was not assembled correctly, misused, overloaded or which has been used or operated contrary to our instructions, or which has been repaired or altered by anyone other than an authorized representative.

Warranty Exclusions

Warranty will not cover:

- Pieces worn out due to normal wear and tear.
- Misuse, negligence of care, and lack of maintenance.
- Failures due to using non genuine replacement parts.

Warranty will be voided if the machine has been modified in any way.

Parts Illustration List

Section A. Main Body

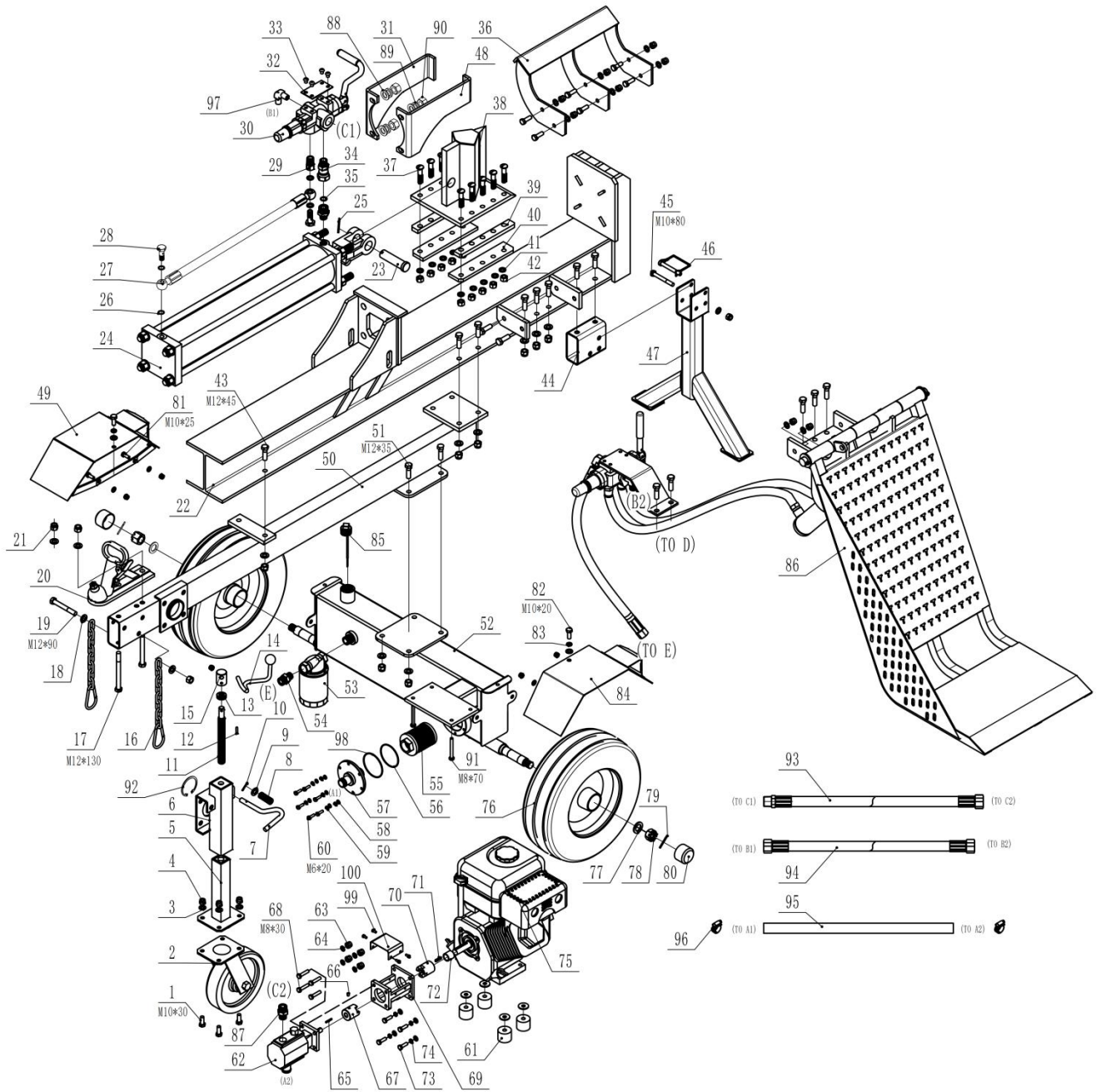

Parts Illustration List

Ref #	Part No.	Description	Qty
1	BWMLSD300001-2026	Hex Bolt M10x30	10
2	BWMLSD300002-2026	Jockey Wheel 8"	1
3	BWMLSD300003-2026	Flat Washer Ø10	21
4	BWMLSD300004-2026	Nylon Lock Nut M10	19
5	BWMLSD300005-2026	Moving Pipe	1
6	BWMLSD300006-2026	Outer Bushing	1
7	BWMLSD300007-2026	Safety Pin	1
8	BWMLSD300008-2026	Spring	1
9	BWMLSD300009-2026	Flat Washer Ø12	1
10	BWMLSD300010-2026	Cotter Pin Ø3.2x25	1
11	BWMLSD300011-2026	Screw Rod	1
12	BWMLSD300012-2026	Elastic Cylinder Pin	1
13	BWMLSD300013-2026	Thrust Ball Bearing	1
14	BWMLSD300014-2026	Handle Ball	1
15	BWMLSD300015-2026	Jockey Wheel Handle Bushing	1
16	BWMLSD300016-2026	Hook Chain	2
17	BWMLSD300017-2026	Hex Bolt M12x130	2
18	BWMLSD300018-2026	Flat Washer Ø12	25
19	BWMLSD300019-2026	Hex Bolt M12x90	1
20	BWMLSD300020-2026	50mm Coupler	1
21	BWMLSD300021-2026	nylon lock nut M12	24
22	BWMLSD300022-2026	Beam	1
23	BWMLSD300023-2026	Cylinder Pin	1
24	BWMLSD300024-2026	Cylinder	1
25	BWMLSD300025-2026	Cotter Pin Ø5x50	2
26	BWMLSD300026-2026	Combination Washer Ø14	4
27	BWMLSD300027-2026	Hydraulic Hose (Valve - Cylinder)	1
28	BWMLSD300028-2026	Bolt Connector	2
29	BWMLSD300029-2026	Valve Joiner	1
30	BWMLSD300030-2026	Valve	1
31	BWMLSD300031-2026	Left Stripper Plate	1
32	BWMLSD300032-2026	Plate	1
33	BWMLSD300033-2026	Screw M8x16	4
34	BWMLSD300034-2026	Active Connector	1
35	BWMLSD300035-2026	O Ring Ø20x2.5	1
36	BWMLSD300036-2026	Log Cradle	1

Ref #	Part No.	Description	Qty
37	BWMLSD300037-2026	Screw M12x55	10
38	BWMLSD300038-2026	Wedge	1
39	BWMLSD300039-2026	Wedge Spacer	2
40	BWMLSD300040-2026	Wedge Platen	2
41	BWMLSD300041-2026	Spring WasherØ12	10
42	BWMLSD300042-2026	Nylon Lock Nut M12	10
43	BWMLSD300043-2026	Hex Bolt M12x45	17
44	BWMLSD300044-2026	Connecting Frame	1
45	BWMLSD300045-2026	Hex Bolt M10x80	1
46	BWMLSD300046-2026	Fixed Pin	1
47	BWMLSD300047-2026	Support Leg	1
48	BWMLSD300048-2026	Right Stripper Plate	1
49	BWMLSD300049-2026	Left Fender	1
50	BWMLSD300050-2026	Tow Bar	1
51	BWMLSD300051-2026	Hex Bolt M12x35	4
52	BWMLSD300052-2026	Oil Tank	1
53	BWMLSD300053-2026	Return Oil Filter	1
54	BWMLSD300054-2026	Connector	1
55	BWMLSD300055-2026	Oil Filter	1
56	BWMLSD300056-2026	O Ring Ø72x2.4	1
57	BWMLSD300057-2026	Flange	1
58	BWMLSD300058-2026	Flat Washer Ø6	6
59	BWMLSD300059-2026	Spring Washer Ø6	6
60	BWMLSD300060-2026	Hex Bolt M6x20	6
61	BWMLSD300061-2026	Polyurethane Block	4
64	BWMLSD300064-2026	Gear Pump	1
65	BWMLSD300065-2026	Nylon Lock Nut M8	8
66	BWMLSD300066-2026	Flat Washer Ø8	12
67	BWMLSD300067-2026	Gear Pump Flat Key	1
68	BWMLSD300068-2026	Screw M6x10	1
69	BWMLSD300069-2026	Gear Pump Coupler	1
70	BWMLSD300070-2026	Hex Bolt M8x30	4
71	BWMLSD300071-2026	Gear Pump Stand	1
72	BWMLSD300072-2026	Engine Coupler	1
73	BWMLSD300073-2026	Engine Flat Key	1

Ref #	Part No.	Description	Qty
74	BWMLSD300074-2026	Spring Washer Ø8	4
75	BWMLSD300075-2026	Engine	1
76	BWMLSD300076-2026	Wheel	2
77	BWMLSD300077-2026	Flat Washer Ø20	2
78	BWMLSD300078-2026	Hex Slotted NutM20x1.5	2
79	BWMLSD300079-2026	Cotter Pin Ø4x40	2
80	BWMLSD300080-2026	Axle Cap	2
81	BWMLSD300081-2026	Hex Bolt M10x25	4
82	BWMLSD300082-2026	Hex Bolt M10x20	2
83	BWMLSD300083-2026	Spring Washer Ø10	2
84	BWMLSD300084-2026	Right Fender	1
85	BWMLSD300085-2026	Oil Plug	1
86	BWMLSD300086-2026	Lifting Plate assembly	1
87	BWMLSD300087-2026	Pump Connector	1
88	BWMLSD300088-2026	Flat Washer Ø18	4
89	BWMLSD300089-2026	Spring Washer Ø18	4
90	BWMLSD300090-2026	Nylon Lock Nut M18	4
91	BWMLSD300091-2026	Hex Bolt M8x70	4
92	BWMLSD300092-2026	Clamp	1
93	BWMLSD300093-2026	Hydraulic Hose (Valve - Pump)	1
94	BWMLSD300094-2026	Hydraulic Hose (Valve - Valve)	1
95	BWMLSD300095-2026	Oil Pipe	1
96	BWMLSD300096-2026	Clamp	2
97	BWMLSD300097-2026	Angle Connector	2
98	BWMLSD300098-2026	O Ring Ø80x2.4	1
99	BWMLSD300099-2026	Hex Bolt M5x10	4
100	BWMLSD300100-2026	Pump Cover	1

Section B. Lifting Table

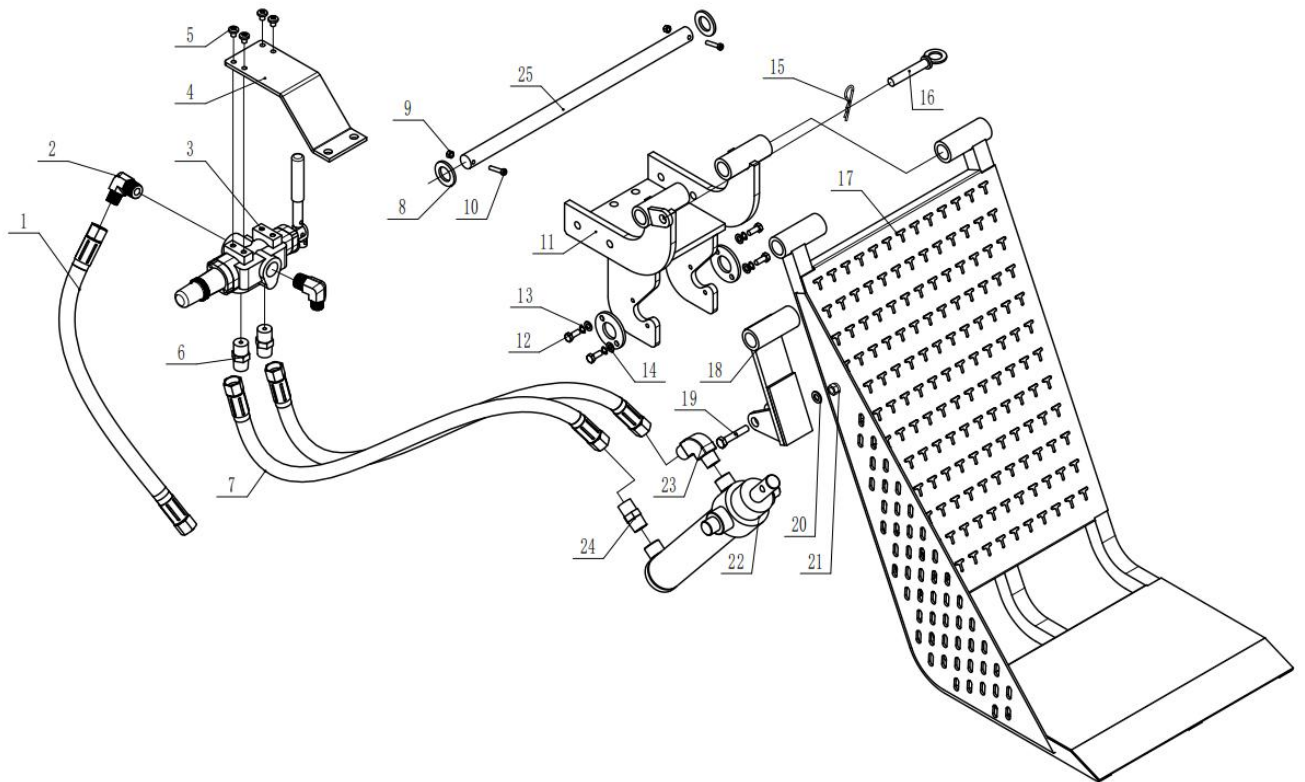

Ref #	Part No.	Description	Qty
86-1	BWMLSFLT00001	Hydraulic Hose (Valve – Oil Tank)	1
86-2	BWMLSFLT00002	Valve Angle Connector	2
86-3	BWMLSFLT00003	Lifting Valve	1
86-4	BWMLSFLT00004	Valve Mounting Plate	1
86-5	BWMLSFLT00005	Screw M8x20	4
86-6	BWMLSFLT00006	Connector	2
86-7	BWMLSFLT00007	Hydraulic Hose	2
86-8	BWMLSFLT00008	Flat Washer Ø24	2
86-9	BWMLSFLT00009	Nylon Lock Nut M6	2
86-10	BWMLSFLT00010	Screw M6x35	2
86-11	BWMLSFLT00011	Connecting Frame	1
86-12	BWMLSFLT00012	Hex Bolt M8x20	4
86-13	BWMLSFLT00013	Spring WasherØ8	4
86-14	BWMLSFLT00014	Flat Washer Ø8	4
86-15	BWMLSFLT00015	R Pin	1
86-16	BWMLSFLT00016	Safety Pin	1

Ref #	Part No.	Description	Qty
86-17	BWMLSDLT00017	Lifting Table	1
86-18	BWMLSDLT00018	Lift Arm	1
86-19	BWMLSDLT00019	Hex Bolt M12x70	1
86-20	BWMLSDLT00020	Flat Washer Ø12	1
86-21	BWMLSDLT00021	Nylon Lock Nut M12	1
86-22	BWMLSDLT00022	Lift Cylinder	1
86-23	BWMLSDLT00023	Cylinder Angle Connector	1
86-24	BWMLSDLT00024	Cylinder Connector	1
86-25	BWMLSDLT00025	Hinge Pin	1

Customer Service:

303 Warrigal Road, Cheltenham, Victoria 3192, Australia

Telephone: 13000 454 585

Website: www.BWMachinery.com.au

Email: admin@bwmachinery.com.au

Spare parts are available from our dealers and our official website