

BWM 30 Ton Log Splitter

(with hydraulic lifting table)

User's Manual

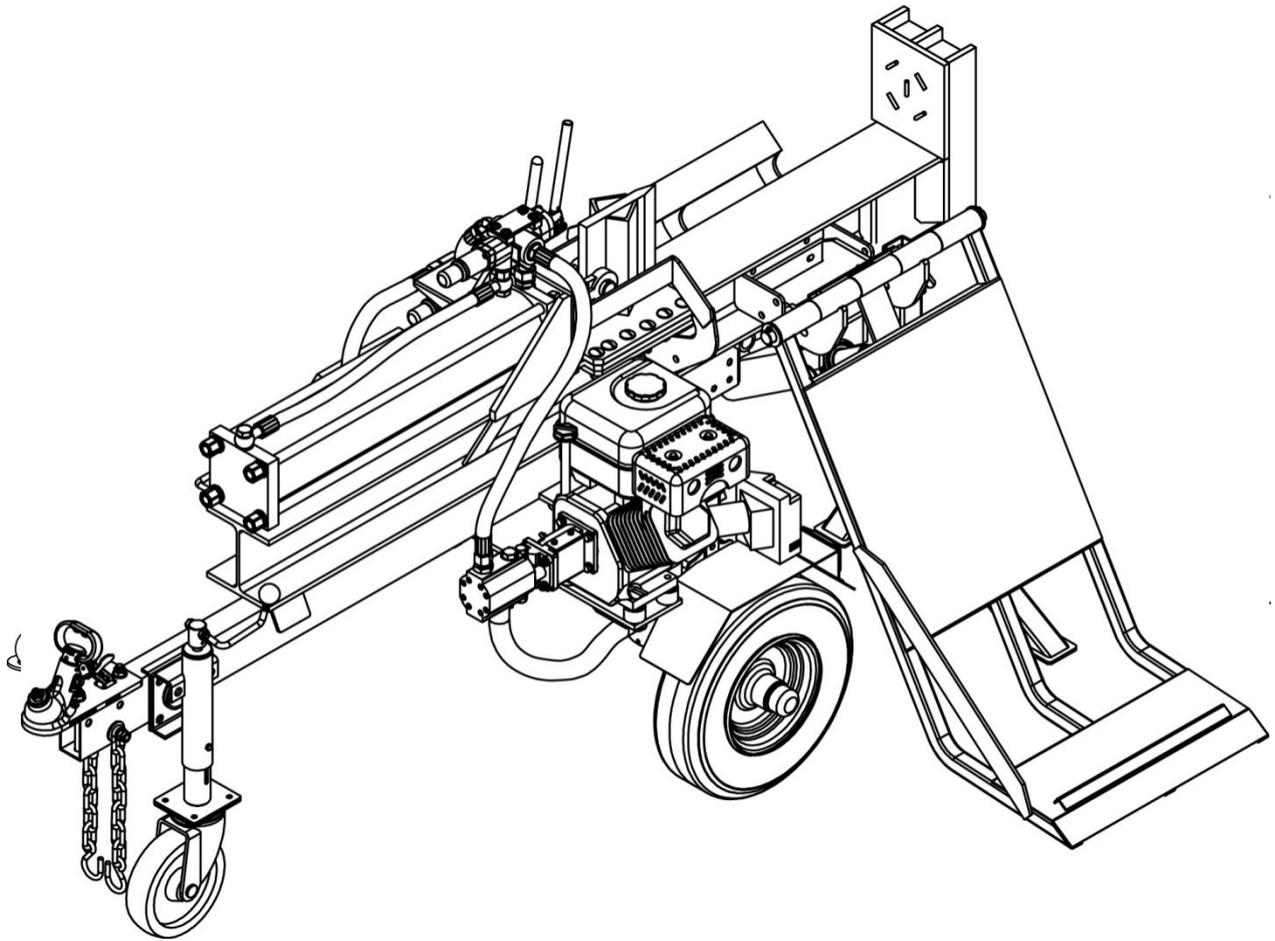

BWM LSD30 Deluxe Series

Please read through this owner's manual carefully before using the product, to ensure the safety of yourself and others.

*Due to continuing improvements, actual product may differ slightly from the product described herein.

Index

1. General Warnings and Rules.....	3
2. Hazard Signal Definitions	4
3. Parts Component	5
3. Controls and Features Identification	5
4. Assembly Instructions.....	8
5. Operating Instructions.....	16
6. Maintenance and Storage.....	20
7. Troubleshooting.....	21
8. Specifications.....	22
9. Warranty	23
10. Illustrated Parts List.....	24



GENERAL WARNINGS



READ and UNDERSTAND this manual completely before using 30 Ton Log Splitter.

Operator must read and understand all safety and warning information, operating instructions, maintenance and storage instructions before operating this equipment. Failure to properly operate and maintain the log splitter could result in serious injury to the operator or bystanders.

Operation Warnings

- Do not at any time carry passengers, sit or stand on the log splitter.
- Do not allow children to play on, stand upon or climb on the log splitter.
- Always inspect the log splitter before using to assure it is in good working condition.
- Replace or repair damaged or worn parts immediately.
- Always check and tighten hardware and assembled parts before operation.
- Do not exceed equipment maximum load capacity of 30 tons.
- Avoid large holes and ditches when towing the equipment.
- Always operate the log splitter on clear and level ground.
- Do not operate the log splitter at night, only during daylight hours.
- Always tow at reduce speed in rough terrain, along creeks, ditches and on hillsides.
- To avoid personal injury and/or equipment damage **DO NOT EXCEED 72 KM/H.**
- Always refer to the vehicle owner's manual for proper towing.
- Always secure and lock the log splitter to the vehicle hitch before towing.

Crush and Cut Hazards

- Always keep hands and feet clear from moving parts while operating the equipment.
- Always clear and keep work area clean and free of debris when operating.
- Always wear safety gear, eye protection, gloves and work boots when operating the log splitter.



WARNING

The warnings, cautions, and instructions outlined in this instruction manual cannot cover all possible conditions or situations that may occur. It must be understood by the operator that common sense and caution are factors which cannot be built into this product and must be supplied by the operator.

Assembly Is Required

This product requires assembly before use. See "Assembly" section for instructions. Because of the weight and/or size of the log splitter, it is recommended that another adult be present to assist with the assembly. **INSPECT ALL COMPONENTS** closely upon receipt to make sure no components are missing or damaged.

Hazard Signal Word Definitions

	<p>This is the safety alert symbol. It is used to alert you to potential personal injury hazards. Obey all safety messages that follow this symbol to avoid possible injury or death.</p>
	<p>DANGER indicates an imminently hazardous situation which, if not avoided, will result in death or serious injury.</p>
	<p>WARNING indicates a potentially hazardous situation which, if not avoided, could result in death or serious injury.</p>
	<p>CAUTION indicates a potentially hazardous situation which, if not avoided, may result in minor or moderate injury.</p>
	<p>CAUTION used without the safety alert symbol indicates a potentially hazardous situation which, if not avoided, may result in property damage.</p>

ABOUT YOUR 30 TON LOG SPLITTER

This hydraulic log splitter has a heavy-duty steel construction and 30 tons of ram force. When there's work to be done, you need outdoor power equipment you can rely on, this log splitter will get the job done fast. It is designed to work in both the horizontal and vertical position. It is easy to tow, easy to use and maintain. Never exceed the rated capacity of 30 tons when operating the log splitter.

Technical specifications on the log splitter are provided in the "Specifications" section of this manual.

Parts Component

Parts Found In Your Log Splitter Box

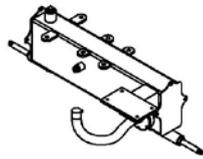

Oil Tank



Wheel

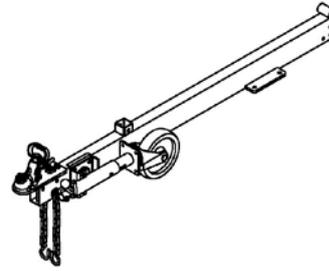

Tow Bar Assembly



Left Fender



Right Fender



Hardware Box

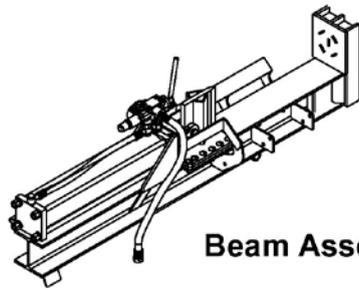

Beam Assembly

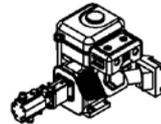

Engine



Oil Drum

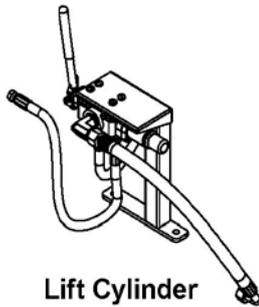

Lift Cylinder Control Valve

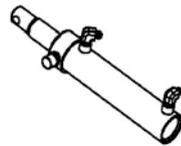

Lift Cylinder



Lift Arm

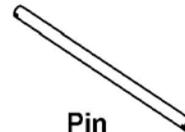

Pin



Hardware Box

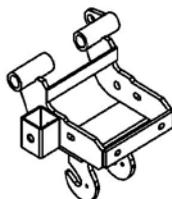

Connecting Farm

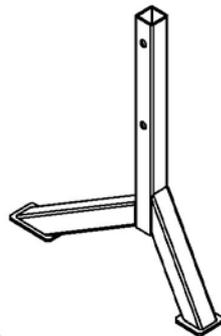

Support Frame

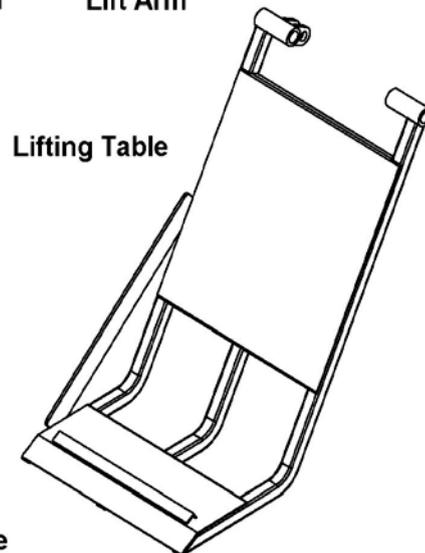

Lifting Table

Controls and Features Identification

Read this owner's manual before operating the equipment. Familiarize yourself with the location and function of the controls and features. Save this manual for future reference.

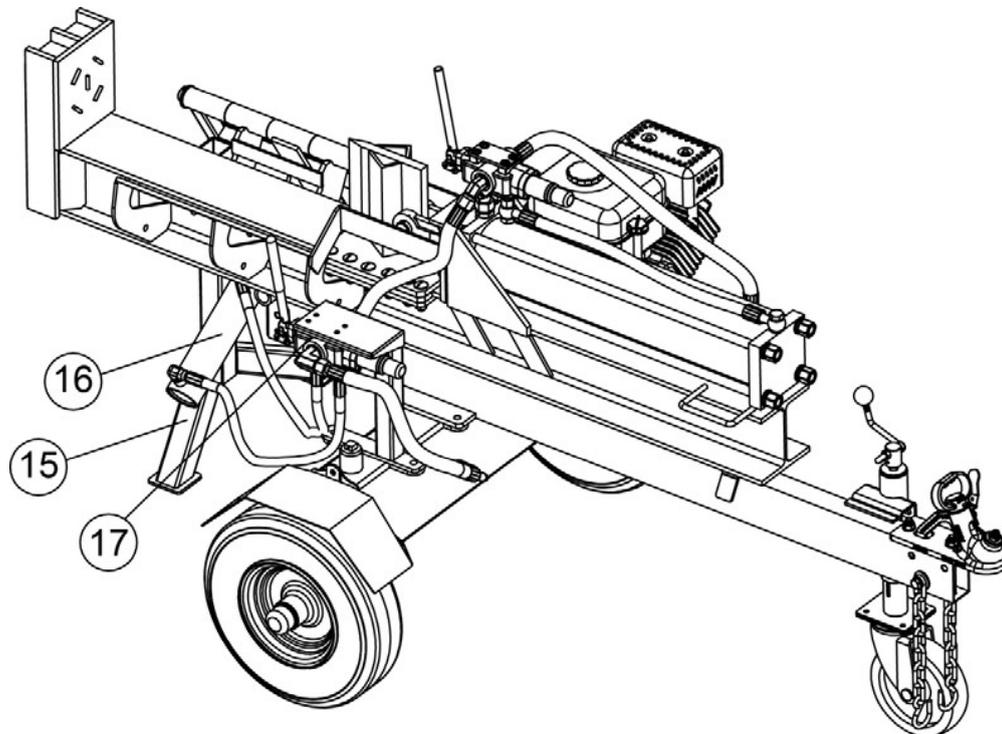
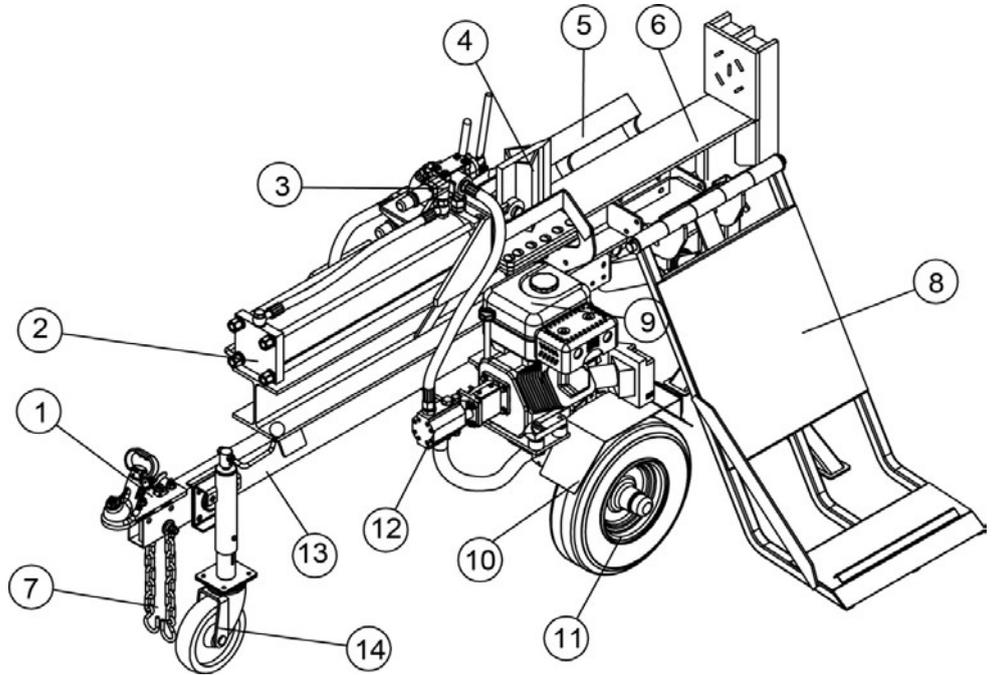

- 1) **50mm Coupler** – Attaches the log splitter to the 50mm hitch ball.
- 2) **Hydraulic Cylinder** –4½” (115mm) bore and a 23” (575mm) stroke.
- 3) **Control Valve Lever** – Controls the forward and backward movement of splitting wedge.
- 4) **8” (20cm) Wedge** - Features wedge wings and tapered ends making splitting easier.
- 5) **Log Cradle** – Keeps the log on the beam without operator assistance.
- 6) **Beam** - 6” (15.2cm) extra wide flange.
- 7) **Safety Chains** – Safety feature to prevent loss of log splitter while towing.
- 8) **Hydraulic Lifting Table**– used to lifting the log
- 9) **Engine** –HONDA GX200, HONDA GP200 or Briggs & Stratton 6.5HP
- 10) Fenders**
- 11) **Tyres** - Maximum rated towing speed is 72KM/H
- 12) **Gear Pump**- Pumps the hydraulic oil through the system.
- 13) Tow Bar**
- 14) **Jockey Wheel** – 8”
- 15) **Rear Support Leg** – The leg supports the log splitter steadily while operating
- 16) **Hydraulic Table Lift Ram** – to lifting and lowering the hydraulic table
- 17) Hydraulic Table Control**

 **WARNING**



Engine Shipped Without Oil.

Before starting engine, fill with 600ml of Briggs SAE30 engine oil or Honda 10W30 engine oil, depending on your model. See engine manual for engine oil capacity.

Hydraulic Oil Tank is Shipped Without Oil.

Add 10L of AW32/AW46 hydraulic oil before the first use. When topping up oil verify the oil level using the Oil filter/Dip Stick on the top of hydraulic oil tank. .

Inspect all Log Splitter Components.

If you have damaged components: Contact the freight company that delivered the log splitter and file a claim.

Read and follow all instructions for assembly and operation. Failure to properly assemble this equipment could result in serious injury to the user or bystanders, or cause equipment damage.

Assembly Instructions

30 TON LOG SPLITTER ASSEMBLY

Set the shipping crate on a solid flat surface and carefully remove the lid. Use two people and take all parts out of the shipping crate and inspect the components to ensure there are no missing pieces before starting to assemble the log splitter follow steps 1 through 8.

TOOLS REQUIRED

- Rubber or Wooden Hammer
- 13mm, 16mm, 17mm, 18mm, 19mm, 24mm, 27mm Wrenches
- Large Adjustable Wrench
- Phillips or Standard Screwdriver
- Pliers

STEP 1: Wheel Assembly

1. Attach the wheels (#28) to the oil tank axle (#18) secure using flat washer $\text{Ø}20$ (#29), slotted nut M20 (#30), cotter pin $\text{Ø}4 \times 36$ (#31) and axle cap (#32).

Note: Use a black plastic bushing to fix the axle cap like below picture. Please cover the black bushing onto the axle cap, and use rubber/wooden hammer knocking the end of the plastic bushing and make the axle cap fixed on wheel.

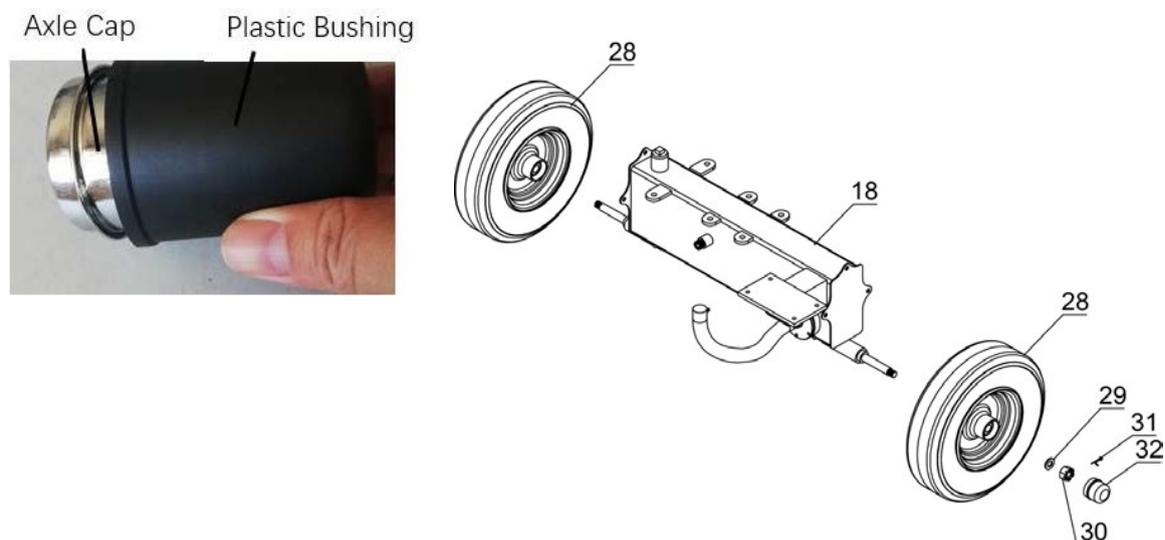

STEP 2: Attach Tow Bar to the Oil Tank

1. Attach tow bar (#64) to the oil tank (#18) and secure using four sets of M12x40 hex bolts (#12), flat washer Ø12 (#3) and nylon lock nut M12 (#13).

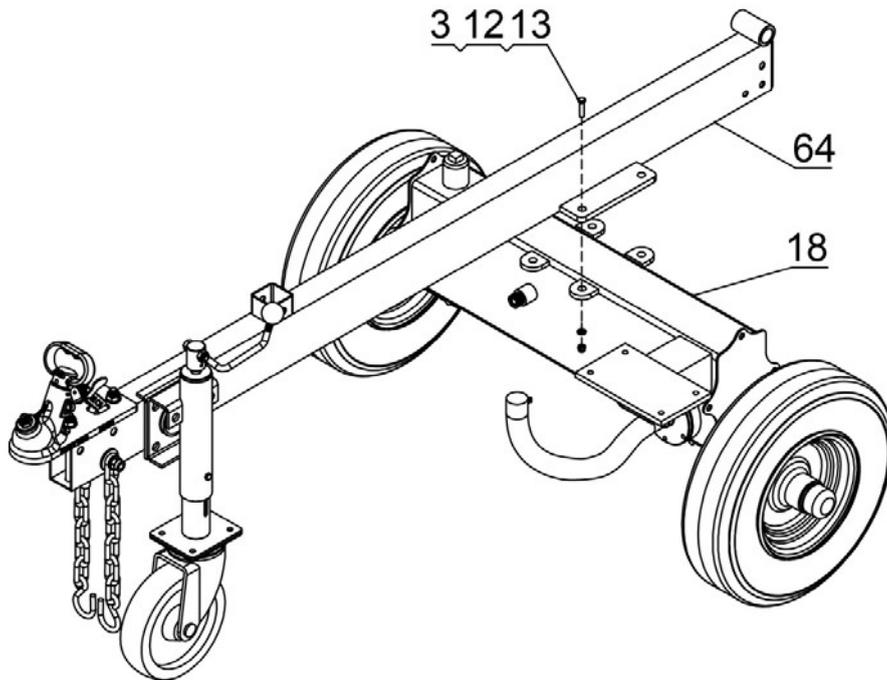

STEP 3: Attach the Wheel Fenders

1. Attach the wheel fenders (#17 & #27) to each side of the oil tank (#18) using M10x30 hex bolt (#22), rubber washer (#23), flat washer Ø10 (#24), lock washer Ø10 (#25) and nylon lock nut M10 (#26).

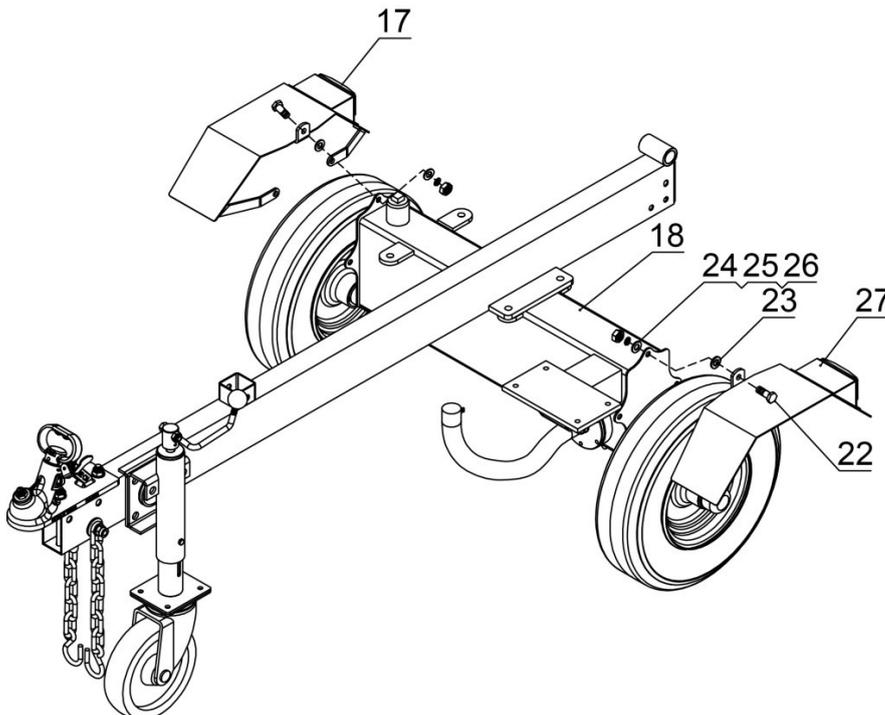

STEP 4: Attach the Beam Assembly to the Tow Bar

1. Attach the beam (#11) to the tow bar (#64), using a hinge pin (#14) and secure with cotter pin $\text{\O}4\times40$ (#15).

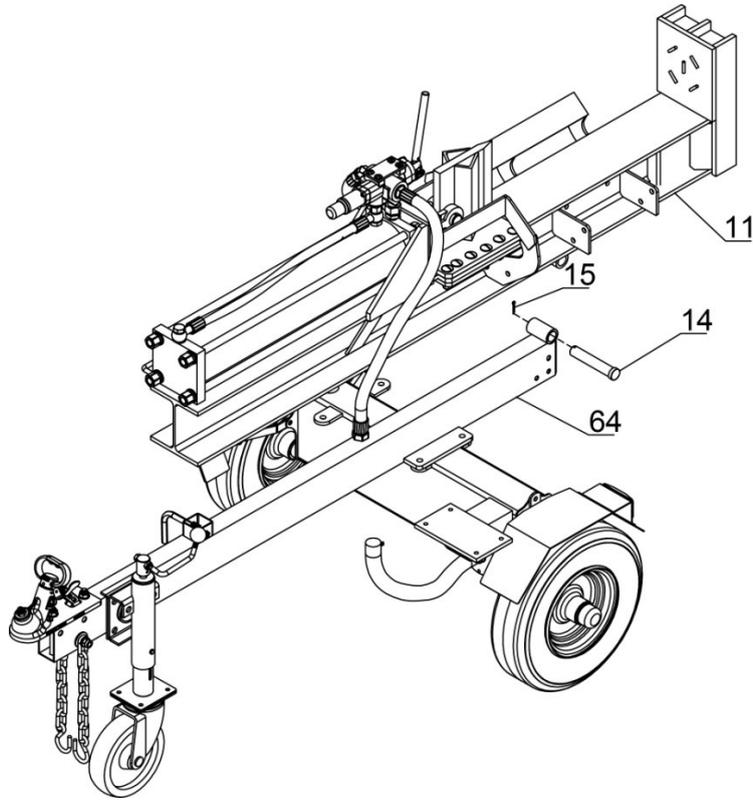

STEP 5: Attach the Engine and Pump

1. Attach the engine (#19) to the oil tank using hex bolt M8x75 (#33), flat washer Ø8 (#34), lock washer Ø8 (#35) and nylon lock nut M8 (#36).
2. Place the blocks (#21) and big flat washers Ø10 (#20) between the engine and mounting plate.

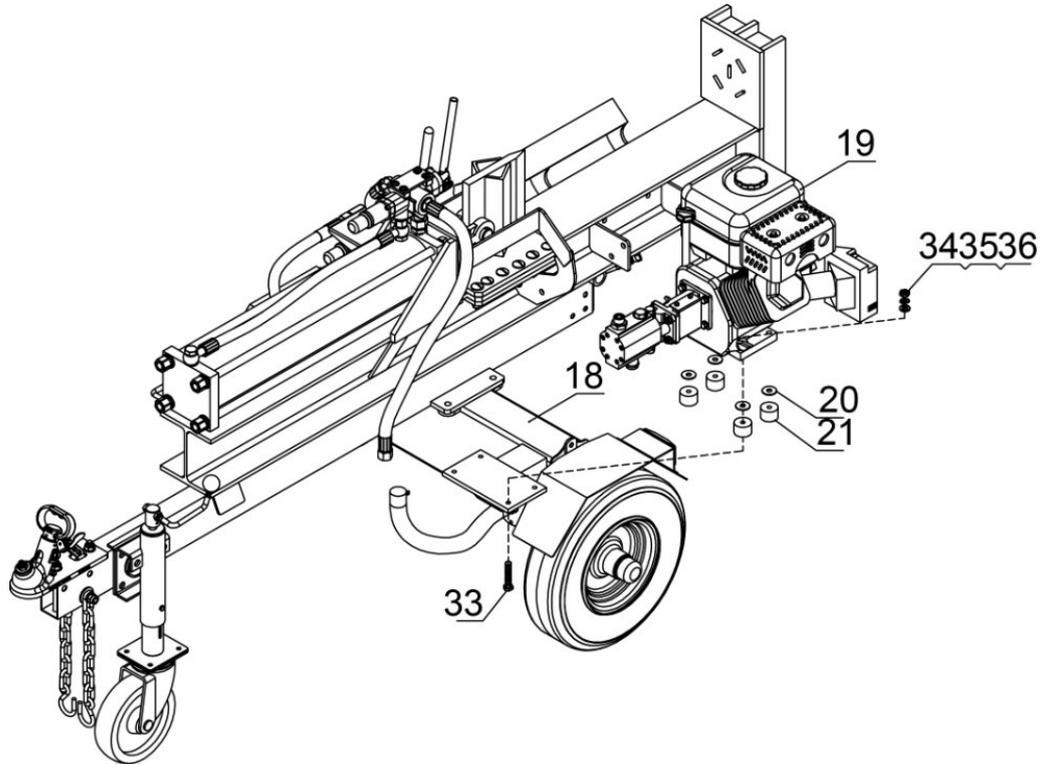

NOTE: If you insert the bolts from the bottom plate, secure them using duct tape to hold them in place while lining up the engine holes with the bolts. Remove the tape from the bottom of the mounting plate once tightened.

STEP 6: Attach Hydraulic Hose Fenders

1. Attach hydraulic hose (#41) to the gear pump connector, tighten with clamp (#40).

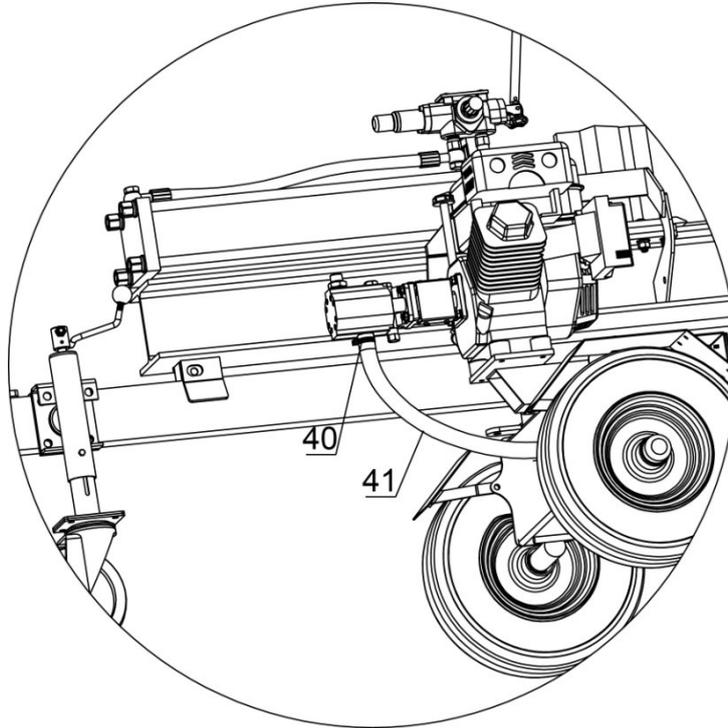

STEP 7: Attach the Support Leg and Connecting Frame

1. Attach the support leg (#105-1) to the connecting frame (#105-3) using bolt (#105-21) and R Pin (#105-19).
2. Attach the connecting frame (#105-3) to the beam using hex bolt M10x30 (#22), flat washer $\text{\O}10$ (#24) and nylon lock nut M10 (#26).

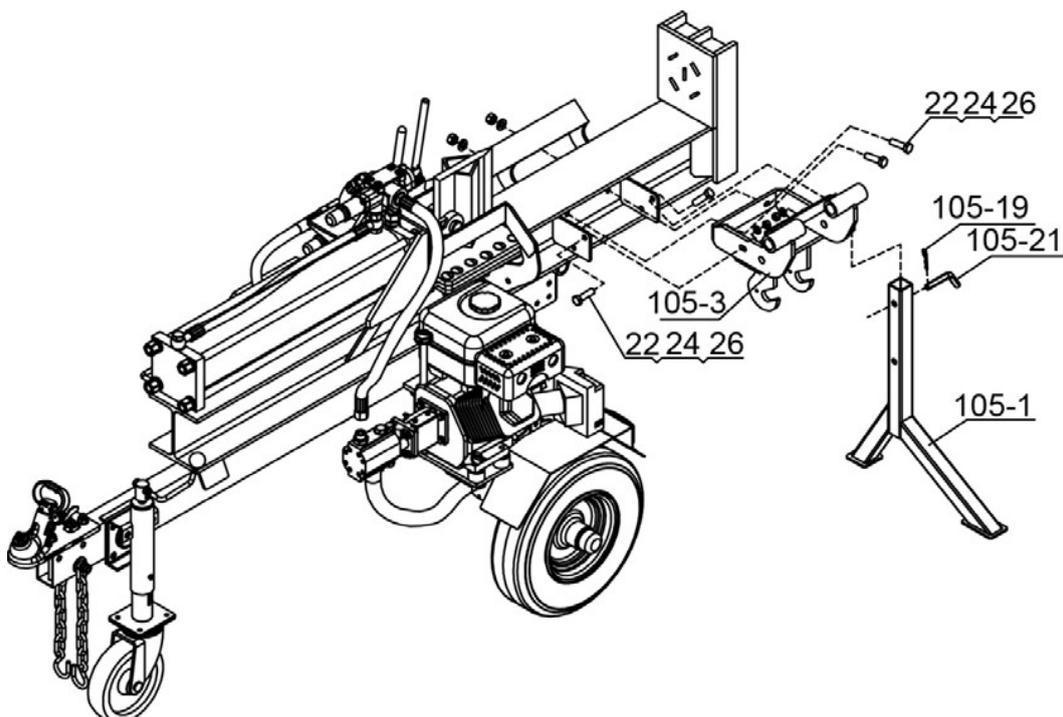

STEP 8: Attach the Lifting Table and Lift Cylinder

1. Attach the lifting table (#105-2) and lift arm (#105-23) to the connecting frame (#105-3) using hinge pin (#105-6), washer (#105-16), screw M5x30 (#105-14) and nylon lock nut M5 (#105-15).
2. Attach the lift cylinder (#105-5) to the lift arm (#105-23) using nylon lock nut M16 (#105-27) and hex bolt M16x70 (#105-28).
3. Attach the lift cylinder (#105-5) to the connecting frame (#105-3) using safety piece (#105-24), flat washer $\varnothing 8$ (#105-25), lock washer $\varnothing 8$ (#105-18) and hex bolt M8x16 (#105-26).

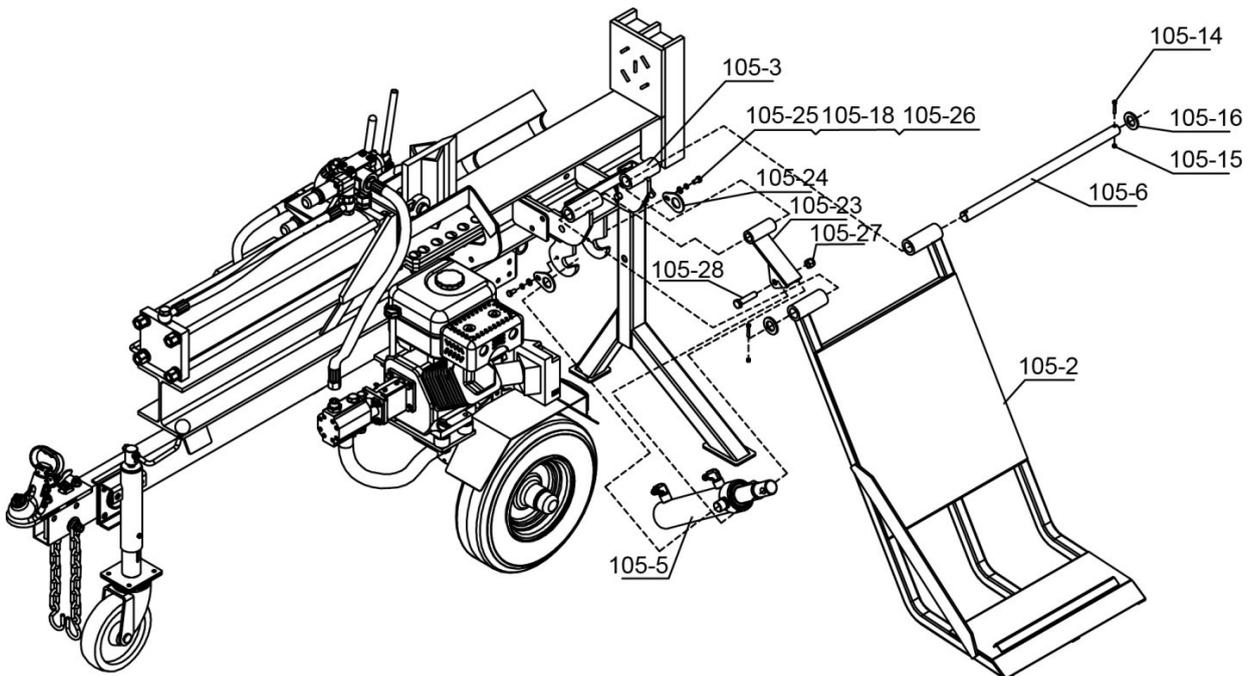

STEP 9: Attach the Lift Cylinder Control Valve and Hydraulic Hose

1. Attach the lift cylinder control valve to the oil tank using hex bolt M12x40 (#12), flat washer \varnothing 12 (#3), nylon lock nut M12 (#13).
2. Connect the hydraulic hose (valve-gear pump) (#55) to the gear pump outlet connector using O Ring \varnothing 11x2.5 (#54).
3. Connect the hydraulic hose (valve-oil tank) (#105-9) to the oil tank connector using O Ring \varnothing 14x2.5 (#61).
4. Connect the hydraulic hose (valve-valve) (#104) to the control valve connector using O Ring \varnothing 14x2.5 (#61).
5. Connect the hydraulic hose (#105-7) to the lift cylinder connector A.
6. Connect the hydraulic hose (#105-7) to the another lift cylinder connector B.

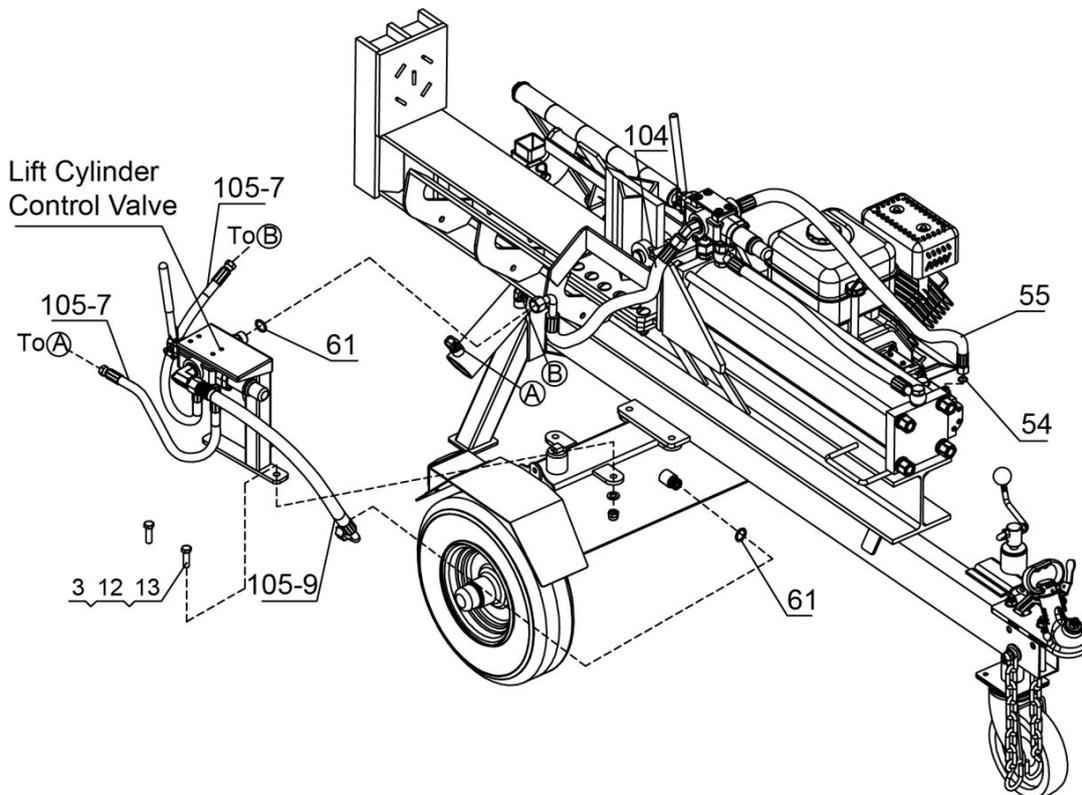

STEP 10: Add Engine Oil

1. Make sure the log splitter is on a level surface.
2. Unscrew the oil fill cap/dipstick to add oil.
3. Add 600ml of engine oil (SAE30 or 10W30, depending on your model). Refer to owner's engine manual for more details. Replace the oil fill cap/dipstick.
4. Check engine oil level each use and add as needed.

NOTE: During the break-in period check the engine oil level more often.

CAUTION

DO NOT attempt to crank or start the engine before it has been properly filled with the recommended type and amount of oil. Damage to the log splitter as a result of failure to follow these instructions will void your warranty.

STEP 11: Add Fuel to the Engine

1. Use only clean, fresh, regular unleaded 91 fuel.
2. DO NOT mix oil with fuel.
3. Remove the fuel cap and slowly add fuel to the tank. DO NOT overfill, allow approximately ¼ inch of space for fuel expansion.
4. Screw on the fuel cap and wipe away any spilled fuel.

DANGER

Log splitter engine exhaust contains carbon monoxide, a colourless, odourless, poison gas. Breathing carbon monoxide will cause nausea, dizziness, fainting or death. If you start to feel dizzy or weak, get to fresh air immediately.

Operate log splitter outdoors only in a well ventilated area.

DO NOT operate the log splitter inside any building, enclosure or compartment.

DO NOT allow exhaust fumes to enter a confined area through windows, doors, vents or other openings.

DANGER: CARBON MONOXIDE, using a log splitter indoors **CAN KILL YOU IN MINUTES.**

CAUTION

Fuel and fuel vapors are highly flammable and extremely explosive.

Fire or explosion can cause severe burns or death.

Unintentional startup can result in entanglement, traumatic amputation or laceration.

Only use regular unleaded 91 fuel.

DO NOT mix oil and petrol together.

Fill tank approximately ¼" below the top of the tank to allow for fuel expansion.

DO NOT fill fuel tank indoors or when the engine is running or hot.

DO NOT light cigarettes or smoke when filling the fuel tank.

STEP 12: Add Hydraulic Oil

1. The log splitter needs to be on a flat, level surface before adding the hydraulic oil.
2. Remove the oil cap from the hydraulic oil tank.
3. Add 10 liters of AW32/AW46 hydraulic oil.
4. Check the hydraulic oil level.
5. Start engine and use the control lever to extend and retract wedge several times to remove air from the lines.
6. With the wedge retracted, check hydraulic oil level again and fill if necessary.

WARNING

DO NOT remove the hydraulic oil fill cap when the engine is running or hot. Hot oil can escape causing severe burns. Always allow the log splitter to cool completely before removing the hydraulic oil cap.

High fluid pressure and temperatures are created in the hydraulic log splitters. Hydraulic fluid will escape through a pin-size hole opening and can puncture skin and cause severe blood poisoning.

Inspect hydraulic system regularly for possible leaks. **Never check for leaks with your hand while the system is pressurized. Seek medical attention immediately if injured by escaping fluid.**

Make sure all fittings are tight and secure before applying pressure. Relieve system pressure before servicing.

Make sure the hydraulic hoses do not touch any hot surfaces or cutting areas.

Hoses need to be positioned where they are clear from the engine and cutting wedge. To avoid serious bodily injury always inspect the hoses before operating the log splitter.

Operating Instructions

! WARNING

Before operating or using the log splitter, review the instructions below and all safety information. Failure to follow these instructions may result in property damage or injury to the operator or bystanders

! WARNING

ALWAYS use the log splitter for its intended use.
ONLY use the log splitter to split wood logs, length wise with the grain.
NEVER modify, alter or change the log splitter in anyway, modifications will void the warranty.
NEVER attach a rope, cable or other device to the control lever on the log splitter.
ONLY operate the log splitter in daylight.
NEVER leave the log splitter unattended while the engine is running.
DO NOT change the splitting position with the engine running. Contact with the muffler can cause serious burns.
ALWAYS make sure the beam is in the locked position.
DO NOT let the beam drop as it could crush fingers or cause damage to the log splitter.
NEVER operate or let anyone else operate, the log splitter while under the influence of alcohol, drugs, or medication.

USING YOUR LOG SPLITTER

1. DO NOT at any time carry passengers, sit or stand on the log splitter.
2. Check the hydraulic oil level and visually inspect all hoses and attachments for problems.
3. Inspect the engine and make sure the engine oil level is correct.
4. Before towing the log splitter the tyres need to be fully inflated.

! TYRE WARNING

DO NOT over inflate tyres. Serious injury can result if tyres explode.
DO NOT tow the log splitter if the tyres are worn or will not hold air.
DO NOT exceed the maximum 72 KM/H towing speed.

5. Refer to the vehicle owner's manual for proper safety and towing instructions.

! TOWING WARNING

Serious injury or death can occur if towing safety rules are not followed.
Always use safety chains, secure and lock the log splitter to the vehicle hitch before moving.
Drive safely. Be aware of the added length of the log splitter.
Never exceed the maximum travel speed of 72 KM/H.
Never ride or transport cargo on the log splitter.
Turn off the vehicle before leaving the log splitter unattended.
Block the log splitter wheels to prevent unintended movement.

6. The log splitter must have at least 2 meters of clearance from combustible material. It needs to be on a dry and level surface with good footing. Do not work on mud, ice, brush or snow.
When using the log splitter the work zone must be maintained at all times.

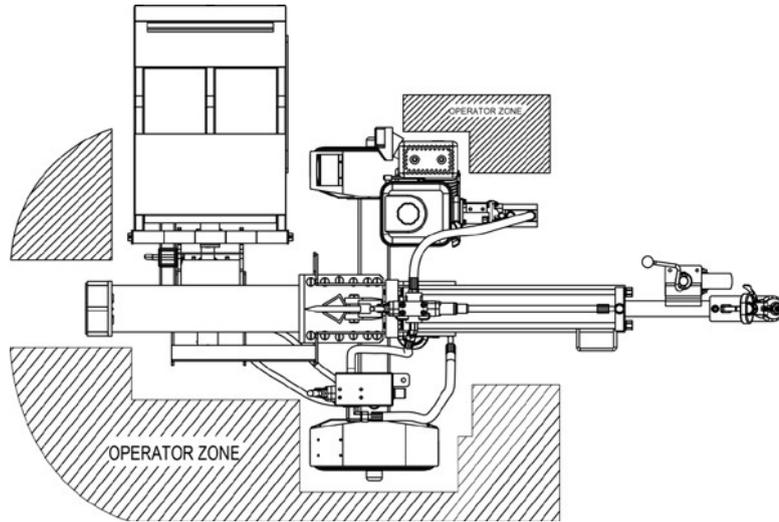

NOTE: Serious accidents can happen when other people are allowed inside the work zone. Keep everyone else outside the work zone while operating the control lever.

7. Always wear safety gear, eye protection, gloves and work boots when operating the log splitter.
8. Start the engine and make sure the log splitter is on level ground before operating.

NOTE: The hydraulic oil needs to be above -12C° before starting the engine. Cold hydraulic oil can damage the hydraulic pump. If outdoor air temperature is below 0C° allow the log splitter to warm up by extending and returning the wedge several times before splitting wood.

9. Put the support leg or jockey wheel in the down position to prevent the log splitter from moving during operation and block both tyres.
10. Set the log splitter in either the horizontal or vertical position.

NOTE: HORIZONTAL position is used for lighter logs that can easily be loaded onto the beam. The VERTICAL position is used for either light logs or heavy logs that are difficult to load onto the beam. Back injury can result from lifting logs onto the log splitter if proper lifting techniques are not used.

11. Load a log onto the beam against the endplate (Max Log Length-24”).

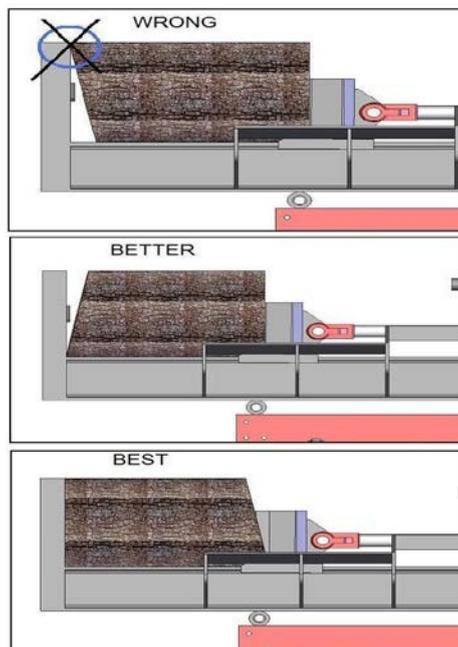

12. Make sure hands are clear from the wedge and crush hazard areas.

CRUSH WARNING

Wedge can cut through skin and break bones. Keep both hands away from wedge and beam slide. Serious accidents can happen when other people are allowed inside the work zone. Keep everyone else out of the work zone while operating control lever.

DO NOT wear loose clothing. It can get tangled in moving parts of log splitter.
Only use the log splitter in daylight so you can see what you are doing.

13. Push control lever FORWARD by one hand to split the log.

14. Push control lever BACKWARD by one hand to return wedge to its original position.

CAUTION

If a log gets stuck, embedded or will not split completely, push the control lever in the reverse direction and allow the splitter to strip the log from the wedge.

If the log still remains stuck, embedded or will not split, turn the machine off and use a sledge hammer and crow bar to remove the log.

ALWAYS keep hands clear of the log and wedge while it is retracting.

15. Always keep work zone clean and free of split wood and debris.

Operating Instructions

HORIZONTAL USING ONLY

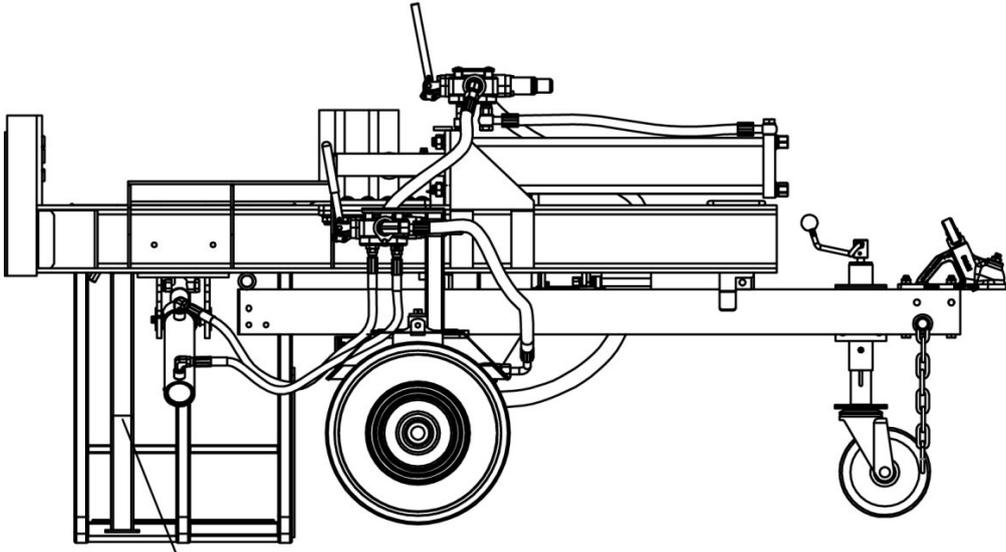

Rotate rear leg down
and slide the lock pin

FOR VEHICLE TOWING

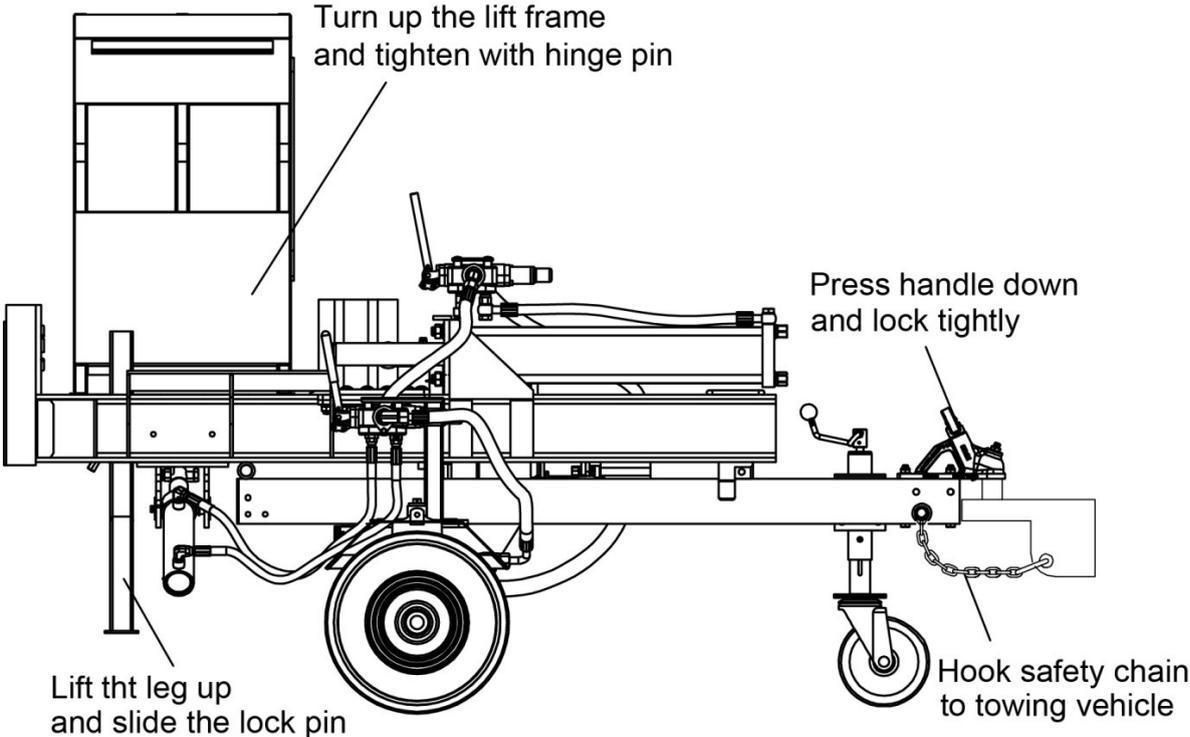

Turn up the lift frame
and tighten with hinge pin

Press handle down
and lock tightly

Lift the leg up
and slide the lock pin

Hook safety chain
to towing vehicle

Maintenance and Storage

CAUTION

Improper maintenance and storage of the log splitter may void your warranty.

MAINTENANCE

- Before performing any maintenance, the log splitter must be placed in maintenance mode. Turn off the engine and move the control lever forward and backwards to relieve the hydraulic pressure.
- After performing any maintenance, make sure all guards, shields and safety features are put back in place before operating the log splitter.
- Before operating make sure the tyres have the RECOMMENDED TYRE PRESSURE.
- Regularly grease axle and wheel bearing area or when needed.
- Periodically check all fasteners and hoses for tightness and leaks.
- Annually clean and lightly lubricate all moving parts or when needed.
- Use a glossy enamel spray paint to touch up scratched or worn painted metal surfaces.
- Never exceed load capacity rating of 30 tons it will damage the log splitter.

What	When	How
Hoses	Each Use	Inspect hoses for exposed wire mesh and leaks. Replace all worn or damaged hoses before starting the engine.
Hydraulic Fittings	Each Use	Inspect fittings for cracks and leaks. Replace all damaged fittings before starting the engine.
Nuts and Bolts	Each Use	Check for loose bolts, tighten before operating.
Beam	Each Use	Apply grease to beam surface.
Moving Parts	Each Use	Clear debris from log splitter.

Refer to the Engine Owner's Manual for engine maintenance.

IMPORTANT:

If a part needs replacement, only use parts that meet the manufacturer's specifications. Replacement parts that do not meet specifications may result in a safety hazard or poor operations.

STORAGE

- Before storing make sure the log splitter is clean and dry for years of trouble-free service.
- Lightly lubricate all log splitter surfaces and moving parts to prevent rust.
- Store indoors or protected area during severe weather and winter months.

Troubleshooting

Problem	
Cylinder rod will not move	SOLUTION: A,D,E,H,J
Slow cylinder rod speed when extending or retracting	SOLUTION: A,B,C,H,I,K,L
Wood will not split or splits extremely slowly	SOLUTION: A,B,C,F,I,K
Engine bogs down during splitting	SOLUTION: G,L
Engine stalls under low load condition	SOLUTION: D,E,L,M
Engine starts problem	SOLUTION: N
Cause	Solution
A -Insufficient oil to pump	Check oil level in reservoir
B -Air in oil	Check oil level in reservoir
C -Excessive pump inlet vacuum	Check pump inlet hose for blockage or kinks
D -Blocked hydraulic lines	Flush and clean the splitter hydraulic system
E -Blocked control valve	Flush and clean the splitter hydraulic system
F -Low control valve setting	Adjust control valve with a pressure gauge
G -High control valve setting	Adjust control valve with a pressure gauge
H -Damaged control valve	Return control valve for authorized repair
I -Internal control valve leak	Return control valve for authorized repair
J -Internal cylinder leak	Return cylinder for authorized repair
K -Internally damaged cylinder	Return cylinder for authorized repair
L -Engine Control out of adjustment	Adjust idle control nuts
M -Engine is loaded during idle down mode	Use shorter log length (26" or less) to allow engine to speed up before contact.
N -Engine operation	Refer to the Engine Owner's Manual

Specifications

Ram Force	30 Ton
Cycle Time	16 Sec
Wedge Size.....	8” Hardened Steel
Hydraulic Tank Capacity.....	10L
Max. Log Length	24” (610mm)
Gear Pump.....	2-Stage
Hydraulic Oil.....	AW32/AW46 Hydraulic Oil
Hydraulic Cylinder	4 1/2” x 23”(115mm x 575mm)
Max. Pressure	3200 PSI
Max. Flow.....	11 GPM
Wheel Size	16” / 4.80 x 8
Hitch Type.....	2” Ball Coupler
Max. Towing Speed.....	72 KM/H
Engine.....	HONDA GX200, HONDA GP200 or Briggs & Stratton 6.5HP

NOTE: For Engine Details Refer to the Engine Owner’s Manual.

Warranty

Limited Warranty

The warranty period for the log splitter is 2 years (Domestic use) and 1 year (commercial use) from the purchase date. The engine has a 3 year warranty. The warranty will not apply to any unit which was not assembled correctly, misused, overloaded or which has been used or operated contrary to our instructions, or which has been repaired or altered by anyone other than an authorized representative.

Warranty Exclusions

Warranty will not cover:

- Pieces worn out due to normal wear and tear.
- Misuse, negligence of care, and lack of maintenance.
- Failures due to using non genuine replacement parts.

Warranty will be voided if the machine has been modified in any way.

Parts Illustration List

Section A. Main Body

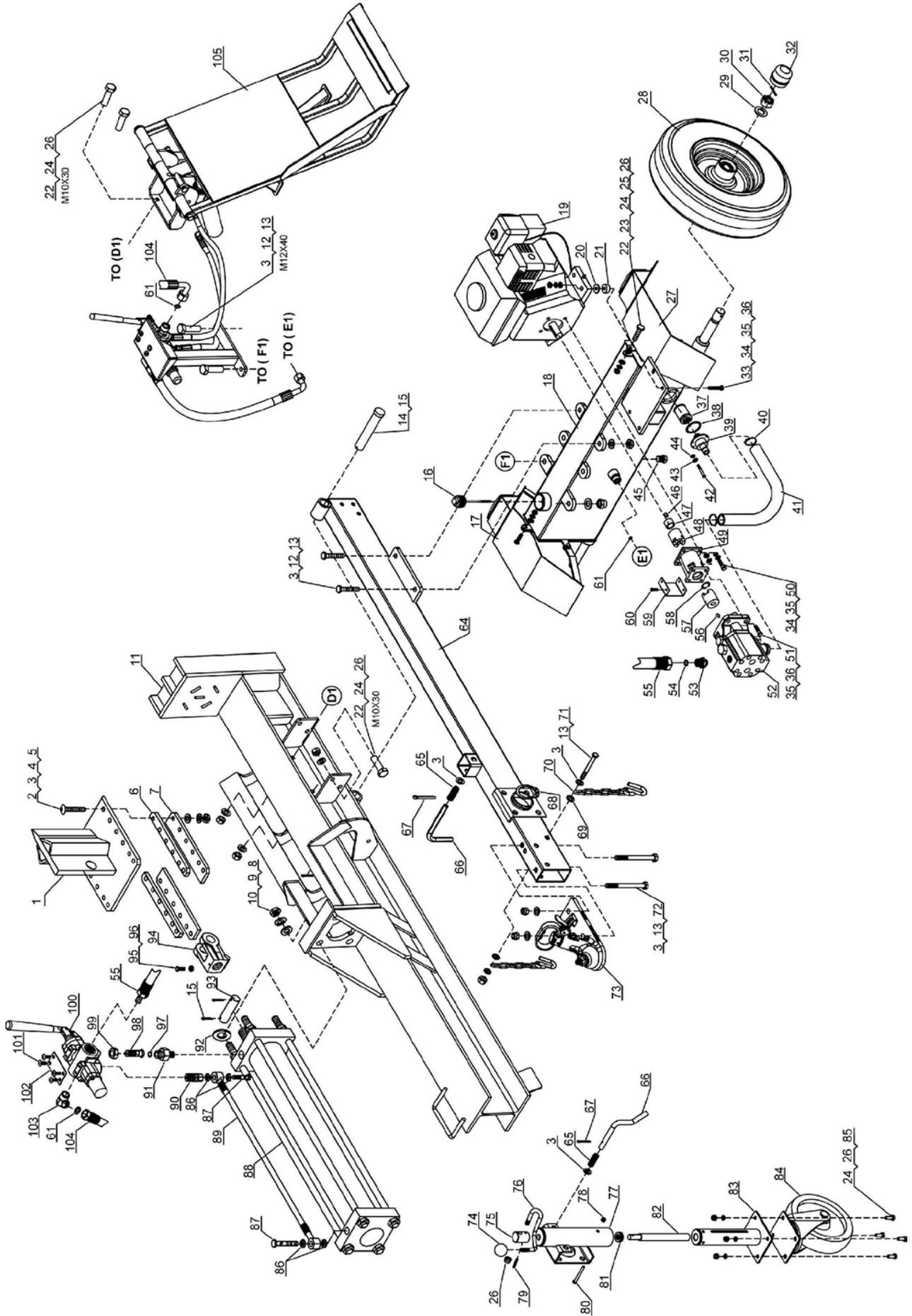

Parts Illustration List

Ref #	Part No.	Description	Qty
1	BWMLSD300001	Beam Weldment	1
2	BWMLSD300002	Screw M12x55	12
3	BWMLSD300003	Flat Washer Ø12	24
4	BWMLSD300004	Lock Washer Ø12	12
5	BWMLSD300005	Thick Nut M12	12
6	BWMLSD300006	Keeper Spacer	2
7	BWMLSD300007	Keeper Plate	2
8	BWMLSD300008	Lock Washer Ø18	4
9	BWMLSD300009	Flat Washer Ø18	4
10	BWMLSD300010	Hex Nut M18	4
11	BWMLSD300011	Beam	1
12	BWMLSD300012	Hex Bolt M12x40	6
13	BWMLSD300013	Nylon Lock Nut M12	9
14	BWMLSD300014	Hinge Pin	1
15	BWMLSD300015	Cotter Pin Ø4x40	3
16	BWMLSD300016	Oil Bolt	1
17	BWMLSD300017	Left Fender	1
18	BWMLSD300018	Oil Tank	1
19	BWMLSD300019	Engine	1
20	BWMLSD300020	Big Flat Washer Ø10	4
21	BWMLSD300021	Polyurethane Block	4
22	BWMLSD300022	Hex Bolt M10x30	10
23	BWMLSD300023	Rubber Washer 2	6
24	BWMLSD300024	Flat Washer Ø10	14
25	BWMLSD300025	Lock Washer Ø10	6
26	BWMLSD300026	Nylon Lock Nut M10	15
27	BWMLSD300027	Right Fender	1
28	BWMLSD300028	Wheel	2
29	BWMLSD300029	Flat Washer Ø20	2
30	BWMLSD300030	Hex Slot Thin Nut M20	2
31	BWMLSD300031	Cotter Pin Ø4x36	2
32	BWMLSD300032	Axle Cap	2
33	BWMLSD300033	Hex Bolt M8x75	4
34	BWMLSD300034	Flat Washer Ø8	8
35	BWMLSD300035	Lock Washer Ø8	12
36	BWMLSD300036	Nylon Lock Nut M8	8

Ref #	Part No.	Description	Qty
37	BWMLSD300037	Oil Filter	1
38	BWMLSD300038	Rubber Washer	1
39	BWMLSD300039	Oil Filter Mounting Plate	1
40	BWMLSD300040	Clamp	2
41	BWMLSD300041	Hydraulic Hose	1
42	BWMLSD300042	Hex Bolt M6x20	6
43	BWMLSD300043	Lock Washer Ø6	6
44	BWMLSD300044	Flat Washer Ø6	6
45	BWMLSD300045	Oil Plug	1
46	BWMLSD300046	Flat Key	1
47	BWMLSD300047	Engine Bushing	1
48	BWMLSD300048	Engine Coupler	1
49	BWMLSD300049	Gear Pump Stand	1
50	BWMLSD300050	Hex Bolt M8x25	4
51	BWMLSD300051	Hex Bolt M8x30	4
52	BWMLSD300052	Gear Pump	1
53	BWMLSD300053	Connector	1
54	BWMLSD300054	O Ring Ø11x2.5	1
55	BWMLSD300055	Hydraulic Hose (Valve – Gear Pump)	1
56	BWMLSD300056	Flat Key	1
57	BWMLSD300057	Gear Pump Coupler	1
58	BWMLSD300058	Circlip for Shaft	1
59	BWMLSD300059	Coupler Cover	1
60	BWMLSD300060	Hex Bolt M5x10	4
61	BWMLSD300061	O Ring 14x2.5	3
64	BWMLSD300064	Tow Bar	1
65	BWMLSD300065	Spring	2
66	BWMLSD300066	Safety Pin	2
67	BWMLSD300067	Cotter Pin Ø3x30	2
68	BWMLSD300068	Steel Wire Snap Ring for Shaft Ø62	1
69	BWMLSD300069	Thick Flat Washer Ø12	2
70	BWMLSD300070	Hook Chain	2
71	BWMLSD300071	Hex Bolt M12x90	1
72	BWMLSD300072	Hex Bolt M12x130	2
73	BWMLSD300073	50mm Coupler	1

Ref #	Part No.	Description	Qty
74	BWMLSD300074	Ball Handle	1
75	BWMLSD300075	Jockey Wheel Handle Bushing	1
76	BWMLSD300076	Jockey Wheel Handle	1
77	BWMLSD300077	Outer Sleeve	1
78	BWMLSD300078	Nylon Lock Nut M6	1
79	BWMLSD300079	Elastic Cylindrical Pin	1
80	BWMLSD300080	Hex Bolt M6x60	1
81	BWMLSD300081	Thrust Ball Bearing	1
82	BWMLSD300082	Screw Rod	1
83	BWMLSD300083	Moving Pipe	1
84	BWMLSD300084	8" Caster	1
85	BWMLSD300085	Hex Bolt M10x25	4
86	BWMLSD300086	Bonded Washer	4
87	BWMLSD300087	Bolt Connector	2
88	BWMLSD300088	Cylinder	1
89	BWMLSD300089	Hydraulic Hose (Valve – Oil Tank)	1
90	BWMLSD300090	Valve A Connector	1
91	BWMLSD300091	Front Cover Connector	1
92	BWMLSD300092	Adjustable Washer C	
93	BWMLSD300093	Wedge Pin	1
94	BWMLSD300094	Piston Rod Connector	1
95	BWMLSD300095	Hex Bolt M8x20	1
96	BWMLSD300096	Hex Nut	1
97	BWMLSD300097	O Ring Ø16x2.5	1
98	BWMLSD300098	Valve B Connector	1
99	BWMLSD300099	Nut	1
100	BWMLSD300100	Control Valve	1
101	BWMLSD300101	Screw M8x10	4
102	BWMLSD300102	Plate	1
103	BWMLSD300103	130°Joint	1
104	BWMLSD300104	Hydraulic Hose (Valve – Valve)	1
105	BWMLSD300105	Lifting Table	1

Section B. Lifting Table

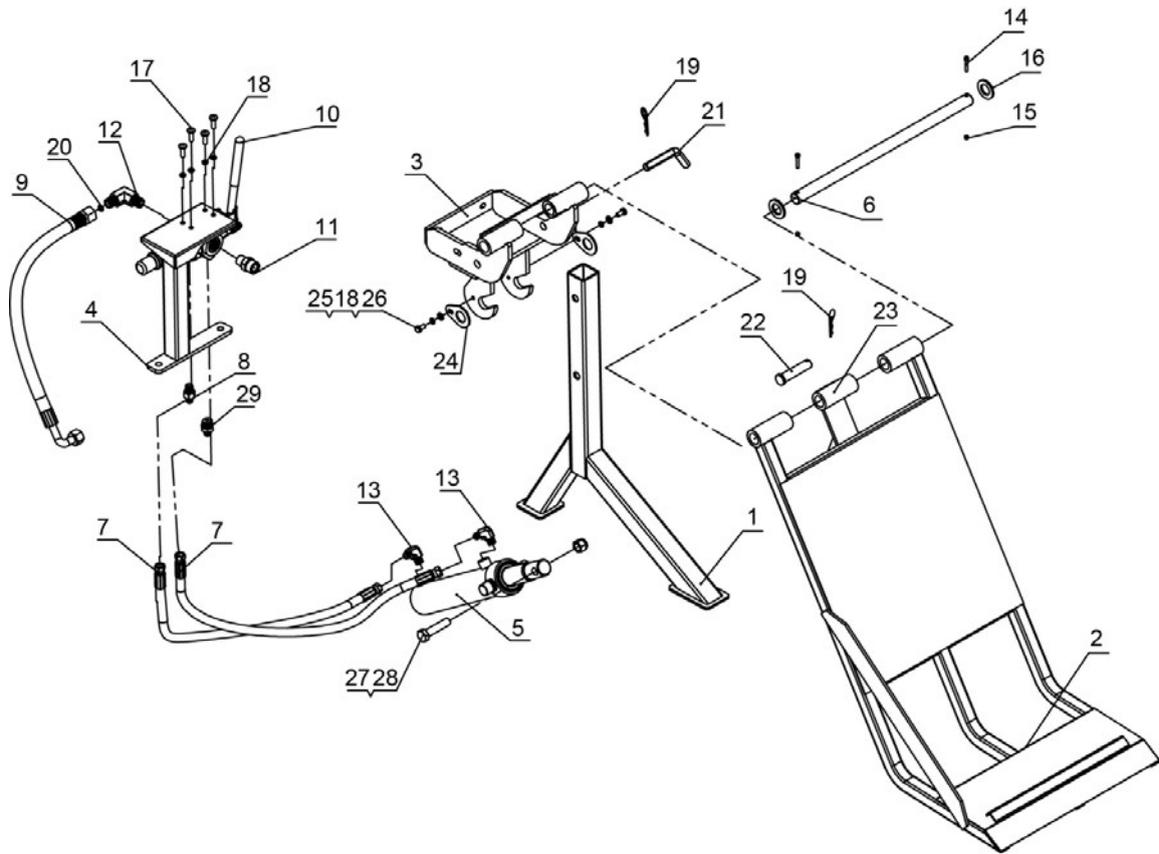

Ref #	Part No.	Description	Qty
1	BWMLSFLT00001	Support Leg	1
2	BWMLSFLT00002	Lifting Table	1
3	BWMLSFLT00003	Connecting Frame	1
4	BWMLSFLT00004	Valve Mounting Plate	1
5	BWMLSFLT00005	Lift Cylinder	1
6	BWMLSFLT00006	Hinge Pin	1
7	BWMLSFLT00007	Hydraulic Hose	2
8	BWMLSFLT00008	Connector	1
9	BWMLSFLT00009	Hydraulic Hose (Valve – Oil Tank)	1
10	BWMLSFLT00010	One-Way Single Handle Control Valve	1
11	BWMLSFLT00011	Connector	1
12	BWMLSFLT00012	Angle Connector	1
13	BWMLSFLT00013	Multi-way Valve Outlet Connection	2
14	BWMLSFLT00014	Screw M5x30	2
15	BWMLSFLT00015	Nylon Lock Nut M5	2
16	BWMLSFLT00016	Washer	2

Ref #	Part No.	Description	Qty
17	BWMLSDLT00017	Screw M8x25	4
18	BWMLSDLT00018	Lock Washer Ø8	6
19	BWMLSDLT00019	R Pin	2
20	BWMLSDLT00020	O Ring Ø14x2.5	1
21	BWMLSDLT00021	Bolt	1
22	BWMLSDLT00022	Safety Pin	1
23	BWMLSDLT00023	Lift Arm	1
24	BWMLSDLT00024	Safety Piece	2
25	BWMLSDLT00025	Flat Washer Ø8	2
26	BWMLSDLT00026	Hex Bolt M8x16	2
27	BWMLSDLT00027	Nylon Lock Nut M16	1
28	BWMLSDLT00028	Hex Bolt M16x70	1
29	BWMLSDLT00029	Connector Z1/2-M14X1.5	1

Customer Service:

303 Warrigal Road, Cheltenham, Victoria 3192, Australia

Telephone: 13000 454 585

Website: www.BWMachinery.com.au

Email: admin@bwmachinery.com.au

Spare parts are available from our dealers and our official website