

BW MACHINERY®

30 TON, 35 TON & 40 TON VERTICAL/HORIZONTAL LOG SPLITTER

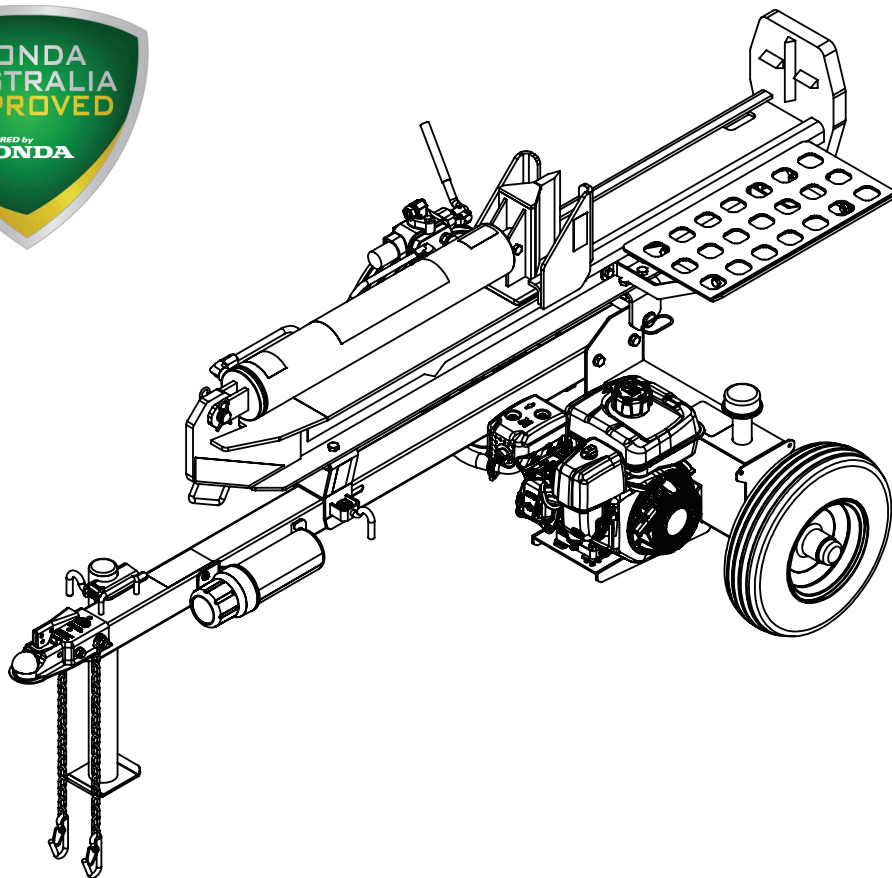

Operation Manual

Model #s BWMLS30H (30 Ton), BWMLS35H (35 Ton), BWMLS40H (40 Ton)



This safety symbol identifies important safety measures throughout this manual. Failure to follow this information may result in serious injury or death.

SAFETY INFORMATION

Intended use	3
Personal protective equipment.....	3
Safety decals	4
General safety	5
Preparation of the log.....	5
Work area.....	5
Operation of the log splitter.....	6
Repairs and maintenance.....	7
Hydraulic safety	7
Fire prevention.....	8
Towing safety.....	8

Assembly Instructions

Assembly Overview	9
Log Catcher Assembly.....	10
1. Unpacking the Container.....	11 - 12
2. Tank and Engine Assembly.....	13
3. Tank and Wheel Assembly	14
4. Tank and Tongue Assembly.....	15
5. Beam Bracket Assembly.....	16
6. Beam and Tank Assembly.....	17
7. Hydraulic Line Connection.....	18
8. Log Catcher Installation.....	19
9. Final Installation Check.....	19

Operating Instructions

Operating Instructions.....	20
Hydraulic Oil Recommendations	20
Engine Oil Recommendations.....	20
Starting Instructions.....	21
Horizontal and vertical operation	22
Maintenance.....	22
Towing.....	23
How to split a log with a slanted surface.....	23

Assembly Details/Parts Lists

Pump/Engine Parts.....	24
Tank Assembly.....	25
Tongue Parts.....	26
Beam Parts.....	27

Specifications & Warranty.....	28
--------------------------------	----

Safety Information **BW**MACHINERY®

WARNING: Read and understand the complete operation manual before assembling or using this product! Failure to comprehend and comply with warnings, cautions and instructions for assembly and operation could result in serious injury or death.



DO NOT permit children to operate this equipment at any time. **DO NOT** permit others that have not read and understood the complete operation manual to operate this equipment. Operation of power equipment can be dangerous. It is the sole responsibility of the operator to understand the assembly and safe operation of this product.



Call us on **1300 454 585** if you have any questions or concerns about the safe operation of this equipment.

INTENDED USE: Do Not Use the log splitter for any purpose other than splitting wood, for which it was designed. Any other use is unauthorized and may result in serious injury or death.



PERSONAL PROTECTIVE EQUIPMENT

When operating this log splitter it is essential that you wear safety gear including goggles or safety glasses, steel toed shoes and tight fitting gloves (no loose cuffs or draw strings). Always wear ear plugs or sound deafening headphones to protect against hearing loss when operating this log splitter.



DO NOT wear loose clothing or jewelry that can be caught by moving parts of the log splitter. Keep clothing and hair away from all moving parts when operating this log splitter.



SAFETY DECALS

Make sure all safety warning decals are attached and in readable condition. Replace missing or defaced decals. Call **1300 454 585** for replacements.

WARNING

To minimize the risk to you or others of serious injury or death:

- Read and understand the owner's manual and engine manual before assembling, operating, towing, or servicing the log splitter.
- Only one person should operate and load logs onto the log splitter. Stay in the manufacturer's designated operator zone. All pets and bystanders should keep away.
- Always wear ANSI approved head, eye, hearing, foot, and hand protection while operating the log splitter.
- Never step or reach over the log splitter during operation.
- Ensure that body, limbs and clothing are away from moving parts while operating the log splitter.
- Always grab logs by the sides when loading.
- Always operate the log splitter outdoors.
- Never use your hands to check for high pressure oil leaks.
- Never operate if tired or under the influence of alcohol or drugs.

OPERATING INSTRUCTIONS

- Ensure that the log splitter is on a stable, flat surface.
- Start the engine and advance throttle to the maximum.
- Position log onto the beam up against the foot plate.

Note: Always split wood in the direction of the grain.

- Move the control handle towards the foot plate to **EXTEND** the wedge or move the control handle away from the foot plate to **RETRACT** the wedge.

CONTROL VALVE OPERATION

RETRACT
EXTEND

For repair or service please call 1300 454 585

BWMLS185

Operation Decal
Part # BWMLS185

WARNING

EQUIPMENT OPERATION SHALL ONLY BE PERFORMED IN THE DESIGNATED OPERATOR ZONE BY ONE PERSON.

HORIZONTAL OPERATION
OPERATOR ZONE

VERTICAL OPERATION
OPERATOR ZONE

BWMLS186

Operator Zone Decal
Part # BWMLS186

ATTENTION

FILL WITH AW46 HYDRAULIC FLUID, START ENGINE, CYCLE CYLINDER 3 - 4 TIMES, STOP ENGINE & REFILL BEFORE OPERATION.

BWMLS188

Hydraulic Fluid Decal
Part # BWMLS188

DANGER

PINCH POINT HAZARD
KEEP CLEAR DURING OPERATION

BWMLS187

Pinch Point Decal
Part # BWMLS187

WARNING

TO AVOID SERIOUS INJURY OR DEATH

- Read the **OPERATION MANUAL** on how to attach the coupler to the hitch ball and how to tow safely.
- Ensure the correct ball size is being used.
- Do not exceed hitch ball or coupler load limits.
- Attach and secure safety chains prior to towing.
- Do not exceed maximum towing speed of 70km/h.
- Avoid sharp turns and steep angles.
- Check tightness of couplers before towing.
- Replace hitch ball or coupler if damaged.

BWMLS189

Warning Decal
Part # BWMLS189

NOTICE

Tank oil level should always be kept between the "MAX" and "MIN" lines indicated on the dipstick. Never fill the reservoir above the "MAX" line. Maximum system capacity is 25 litres, operational capacity is 19 litres. Select oil viscosity based on the outside temperature at the time of operation in the table below.

AW-68	80	100
AW-46	32	60
AW-32	0	20
DEXRON VI	-20	0

F° -20 0 10 20 32 40 50 60 80 100
C° -30 -20 -10 0 10 20 30 40

BWMLS190

Oil Level Decal
Part # BWMLS190

CAUTION

HOT SURFACE
DO NOT TOUCH

BWMLS191

Hot Surface Decal
Part # BWMLS191

GENERAL SAFETY

Failure to follow warnings, cautions, assembly and operation instructions in the Operation Manual may result in serious injury or death.



READ THE OPERATION MANUAL BEFORE USE

- ❑ **DO NOT** permit children to operate this equipment at any time. Do not permit others that have not read and understood the complete operation manual to operate this equipment.
- ❑ Keep all people and pets a minimum of 10 feet away from the work area when operating this log splitter. Only the operator is to be near the log splitter during use.
- ❑ **DO NOT** operate the log splitter when under the influence of alcohol, drugs or medication.
- ❑ **DO NOT** allow a person who is tired or otherwise impaired or not completely alert to operate the log splitter.

PREPARATION OF THE LOG

Both ends of the log should be cut as square as possible to prevent the log from rotating out of the splitter during operation.

Do not split logs greater than 25" (635mm) in length.

WORK AREA

- ❑ **DO NOT** operate the log splitter on icy, wet, muddy or otherwise slippery ground. **ONLY** operate your log splitter on level ground. **Operating on a slope could cause the log splitter to roll over or logs to fall off of the equipment, which could result in injury.**
- ❑ **DO NOT** operate the log splitter in an enclosed area. Exhaust fumes from the engine contain carbon monoxide which can be harmful or deadly when inhaled.
- ❑ **DO NOT** move the log splitter over hilly or uneven terrain without a tow vehicle or adequate help.
- ❑ Use a tire chock or block on the wheels to prevent movement of the log splitter while in operation.
- ❑ Operate the log splitter in daylight or under good artificial light.
- ❑ Keep the work area free of clutter. Remove split wood from around the log splitter immediately after each use to avoid potential tripping.





OPERATION OF THE LOG SPLITTER

Operate the log splitter from within the operation zone as shown in the diagrams below. The operator has the safest and most efficient access to the control valve and the beam in these locations.

Failure to operate the log splitter in this position can result in serious injury or death.

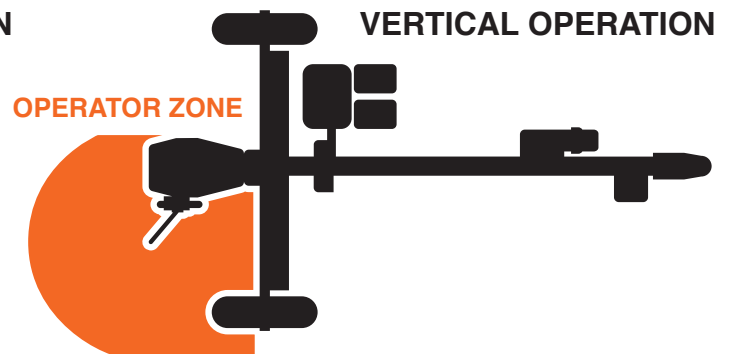

- ❑ Make sure the operator knows how to stop and disengage the controls before operating.
- ❑ Do not place hands or feet between the log and splitting wedge during forward or reverse stroke. Serious injury or death could result.
- ❑ **DO NOT** straddle or step over the log splitter during operation.
- ❑ **DO NOT** reach or bend over the log splitter to pick up a log.
- ❑ **DO NOT** attempt to split two logs on top of each other.
- ❑ **DO NOT** attempt to cross split a log.
- ❑ **DO NOT** attempt to load your log splitter when the ram or wedge is in motion.
- ❑ Use your hand to operate the control lever on the valve. **DO NOT** use your foot, a rope or any extension device.
- ❑ **DO NOT** move the log splitter while the engine is running.
- ❑ **Never leave the equipment unattended while the engine is running.** Shut off the engine even if you are leaving the log splitter for a short period of time.
- ❑ Use your hand to operate the control lever on the valve. **DO NOT** use your foot, a rope or any extension device.

REPAIRS AND MAINTENANCE

- ❑ **DO NOT operate the log splitter when it is in poor mechanical condition or in need of repair.** Frequently check that all nuts, bolts, screws, hydraulic fittings and hose clamps are tight.
- ❑ **DO NOT** alter the log splitter in any manner. Any alteration will void the warranty and could cause the log splitter to be unsafe to operate. Perform all recommended maintenance procedures before using the log splitter. Replace all damaged or worn parts immediately.
- ❑ **DO NOT** tamper with the engine to run it at excessive speeds. The maximum engine speed is preset by the manufacturer and is within safety limits. See Honda engine manual.
- ❑ Remove the spark plug wire before performing any service or repair on the log splitter.
- ❑ **Always check the level of hydraulic oil and engine oil before operation.**
- ❑ Replacement parts must meet manufacturer's specifications.



HYDRAULIC SAFETY

The hydraulic system of the log splitter requires careful inspection along with the mechanical parts. Be sure to replace frayed, kinked, cracked or otherwise damaged hydraulic hoses or hydraulic components.

- ❑ **Check for hydraulic fluid leaks** by passing a piece of paper or cardboard underneath or over the area of the leak. **Do not check for leaks with your hand.** *Fluid escaping from the smallest hole, under pressure, can have enough force to penetrate the skin causing serious injury or death.*
- ❑ **Seek professional medical attention immediately if injured by escaping hydraulic fluid.** Serious infection or reaction can develop if medical treatment is not administered immediately.
- ❑ Relieve all pressure by shutting off the engine and moving the valve control handle back and forth should it become necessary to loosen or remove any hydraulic fitting.
- ❑ **DO NOT** remove the cap from the hydraulic tank or reservoir while the log splitter is running. *The tank could contain hot oil under pressure which could result in serious injury.*
- ❑ **DO NOT** adjust the hydraulic valve. The pressure relief valve on the log splitter is preset at the factory. *Only a qualified service technician should perform this adjustment.*



FIRE PREVENTION

- ❑ **DO NOT** operate the log splitter near an open flame or spark. *Hydraulic oil and fuel are flammable and can explode.*
- ❑ **DO NOT** fill the fuel tank while the engine is hot or running. Allow the engine to cool before refueling.
- ❑ **DO NOT** smoke while operating or refueling the log splitter. Petrol fumes can easily explode.
- ❑ Refuel the log splitter in a clear area with no fuel fumes or spilled fuel. Use an approved fuel container. Replace the fuel cap securely. If fuel has spilled, move the log splitter away from the area of the spill and avoid creating any source of ignition until the spilled fuel has evaporated.
- ❑ Keep a Class B fire extinguisher on hand when operating this log splitter in dry areas as a precautionary measure against possible flying sparks.
- ❑ Drain the fuel tank prior to storage to avoid the potential fire hazard. Store fuel in an approved, tightly sealed container. Store the container in a cool, dry place.
- ❑ Turn the fuel shut off valve on the engine to the “OFF” position before towing the log splitter. Failure to do so may result in flooding the engine.



IMPORTANT NOTE

This log splitter is equipped with an internal combustion engine and should not be used on or near any unimproved forest-covered, brush covered or grass-covered land unless the engine’s exhaust system is equipped with a spark arrester meeting applicable local or state laws (if any). If a spark arrester is used, it should be maintained in effective working order by the operator.

Never operate the log splitter indoors or in a contained are as there is a danger from exhaust fume.



TOWING SAFETY

- ❑ Check all local and state regulations regarding towing, licensing, and lights before towing your log splitter.
- ❑ Check before towing to make sure that the log splitter is correctly and securely attached to the towing vehicle and that the safety chains are secured to the hitch or bumper of the vehicle with enough slack to allow turning. Always use a Class I, 2” ball with this log splitter.
- ❑ **DO NOT** carry any cargo or wood on the log splitter.
- ❑ **DO NOT** allow anyone to sit or ride on the log splitter.
- ❑ Disconnect the log splitter from the towing vehicle before operating it.
- ❑ Use care when backing up with the log splitter in tow to avoid jack-knifing. Allow for added length of the log splitter when turning, parking, crossing intersections and in all driving situations.
- ❑ **DO NOT exceed 70km/h when towing your log splitter.** Towing the log splitter at speeds higher than 70km/h could result in loss of control, damage to the equipment, serious injury or death. Adjust towing speed for terrain and conditions. Be extra cautious when towing over rough terrain especially railroad crossings.

Assembly Overview **BW**MACHINERY®

TOOLS NEEDED FOR ASSEMBLY:

Hammer Needle nose pliers Box cutters #2 Phillips screw driver 6mm hex key wrench
 8mm driver 13mm wrench / socket wrench 17mm wrench / socket wrench 19mm wrench / socket wrench
 22mm & 24mm wrenches / crescent wrench 28mm socket wrench

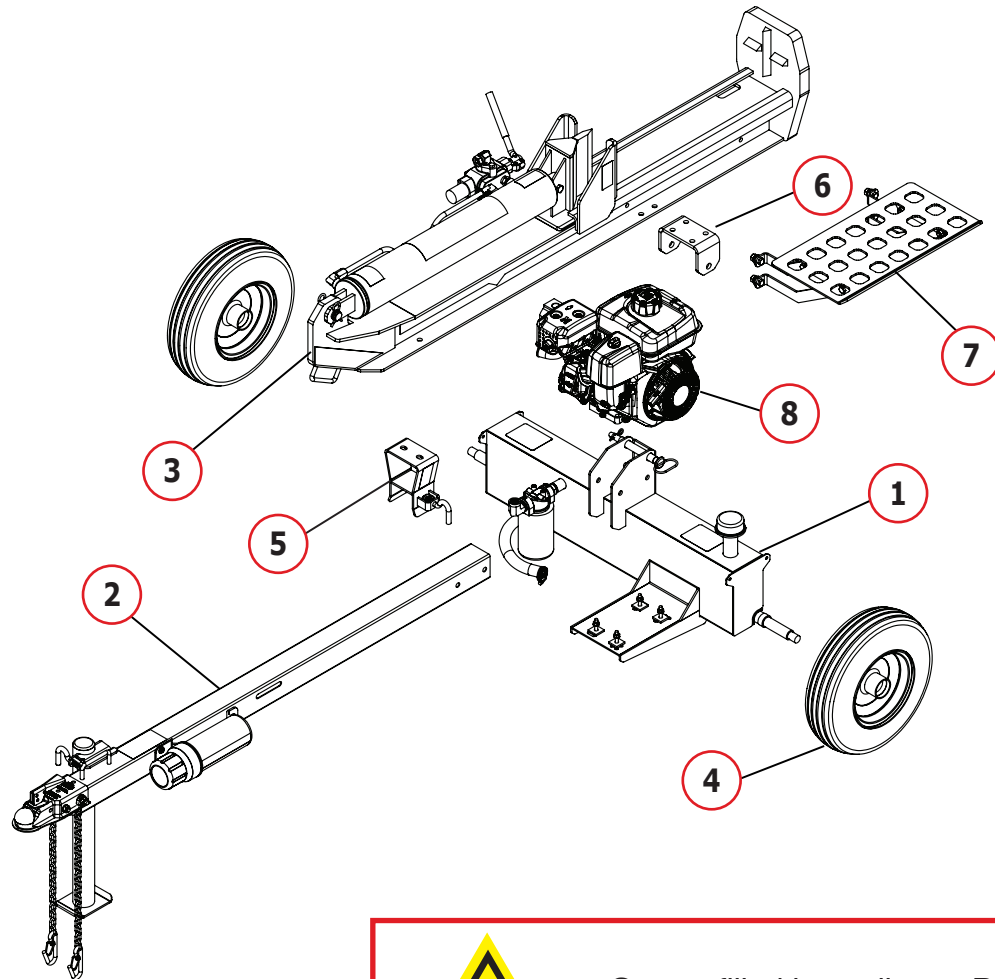

CAUTION

On pre-filled log splitters, **DO NOT REMOVE** the end caps from the hydraulic hoses until Step 7.

No.	Part No.	Description	Qty.
1	BWMLS101	Tank assembly (30 ton)	1
	BWMLS192	Tank assembly (35/40 ton)	
2	BWMLS102	Tongue & stand assembly (30 ton)	1
	BWMLS193	Tongue & stand assembly (35/40 ton)	
3	BWMLS103	Beam & cylinder assembly (30 ton)	1
	BWMLS194	Beam & cylinder assembly (35/40 ton)	
4	BWMLS104	Wheel/tyre assembly, 4.80 x 8"	2

No.	Part No.	Description	Qty.
5	BWMLS105	Beam lock bracket	1
6	BWMLS106	Beam pivot bracket	1
7	BWMLS107	Log catcher assembly	1
8		Honda GP200 or GX200 (30 ton)	1
		Honda GX270 (35 ton)	
		Honda GX390 (40 ton)	

BW MACHINERY® Log Catcher Assembly

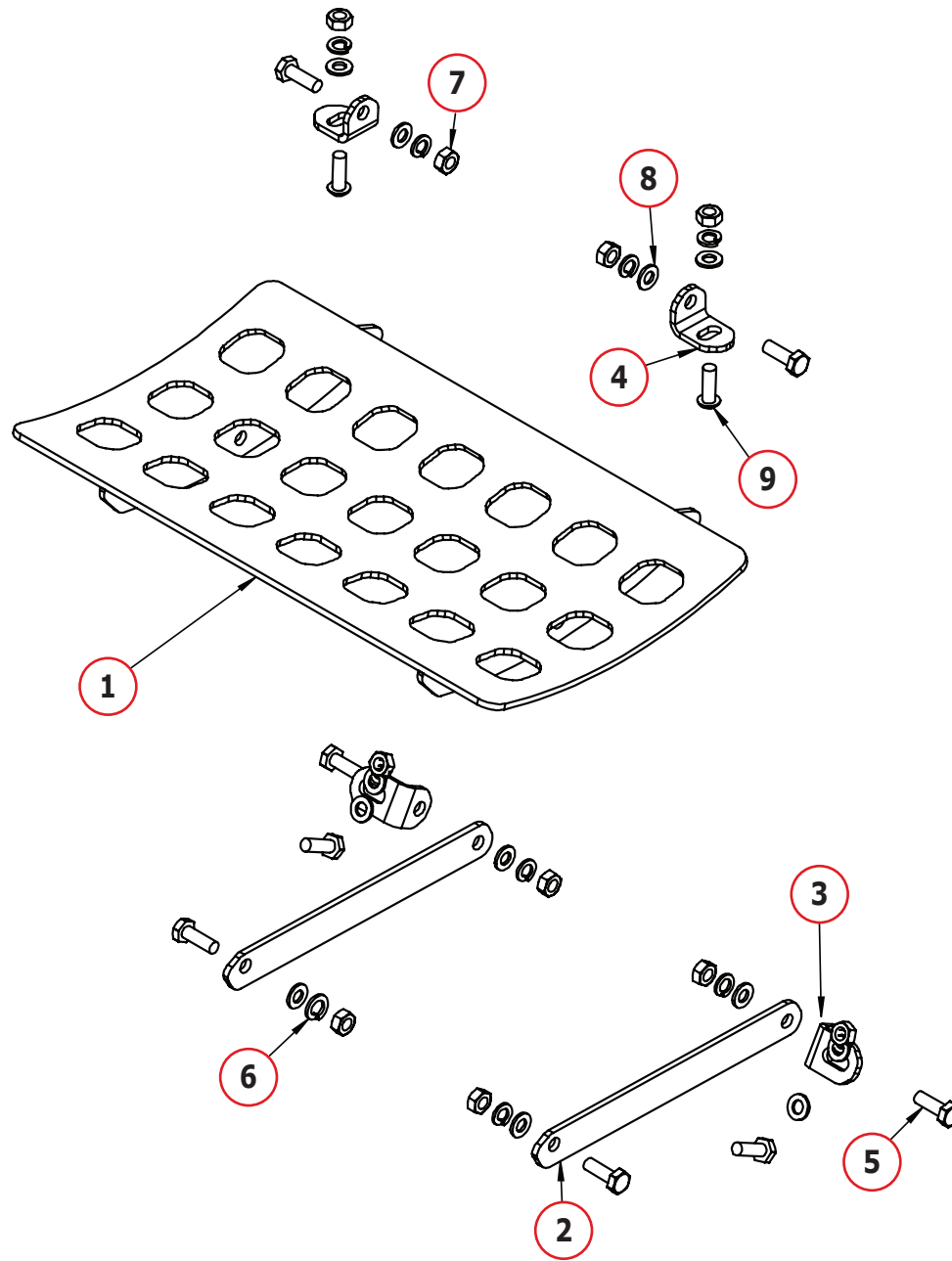

No.	Part No.	Description	Qty.
1	BWMLS108	Log catcher grate	1
2	BWMLS109	Log catcher support plate	2
3	BWMLS110	Log catcher mount, lower	2
4	BWMLS111	Log catcher mount, upper	2
5	BWMLS112	Hex bolt, M10 x 30mm	8

No.	Part No.	Description	Qty.
6	BWMLS113	Lock washer, M10	10
7	BWMLS114	Hex nut, M10	10
8	BWMLS115	Flat washer, M10	12
9	BWMLS116	Button head screw, M10 x 30mm	2

1 - Unpacking the Container **BW**MACHINERY®

Step 1.1

Remove plastic wrap on crate.

Step 1.2

Remove restraining bolts from the beam. Use a 13mm wrench / socket wrench to remove the two hex bolts that are securing the beam to the crate bottom (right). Please note that the two hex bolts are located diagonally opposed to each other.

Step 1.3

Remove beam and cylinder assembly from crate with assistance of a helper. Lift beam and cylinder assembly to its vertical position standing upright on the beam's footplate.

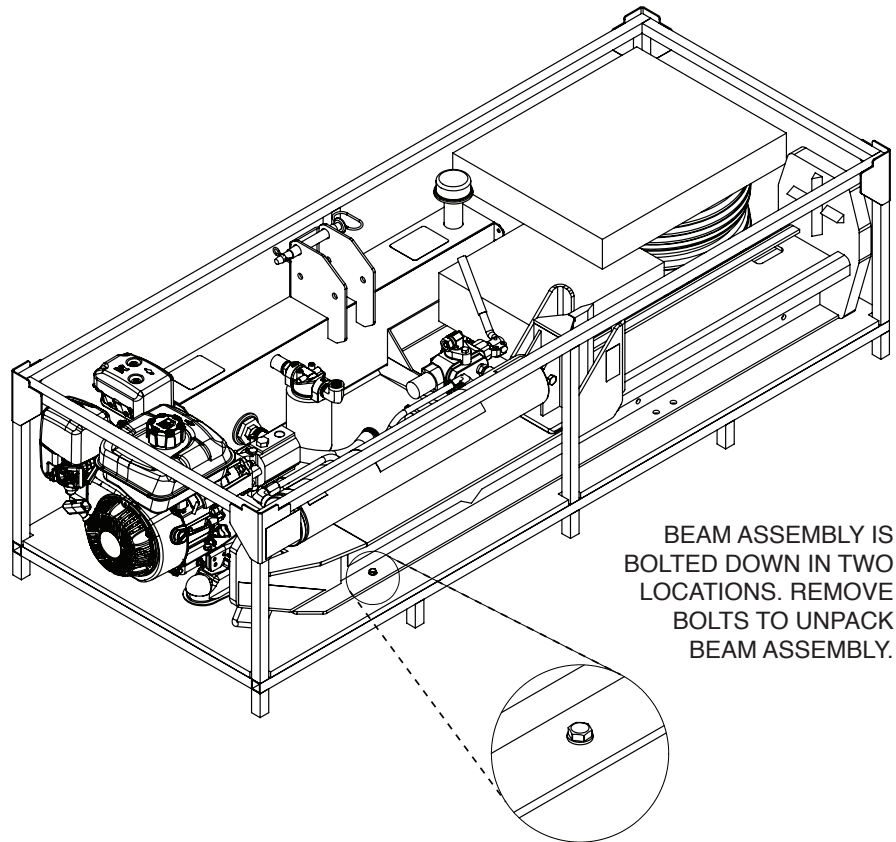

USE CAUTION
WHEN LIFTING -
HEAVY WEIGHT!



TEAM
LIFT
HEAVY
WEIGHT

Step 1.4

Use a 13mm wrench / socket wrench to remove the single hex bolt that is securing the tank assembly to the crate bottom (right).

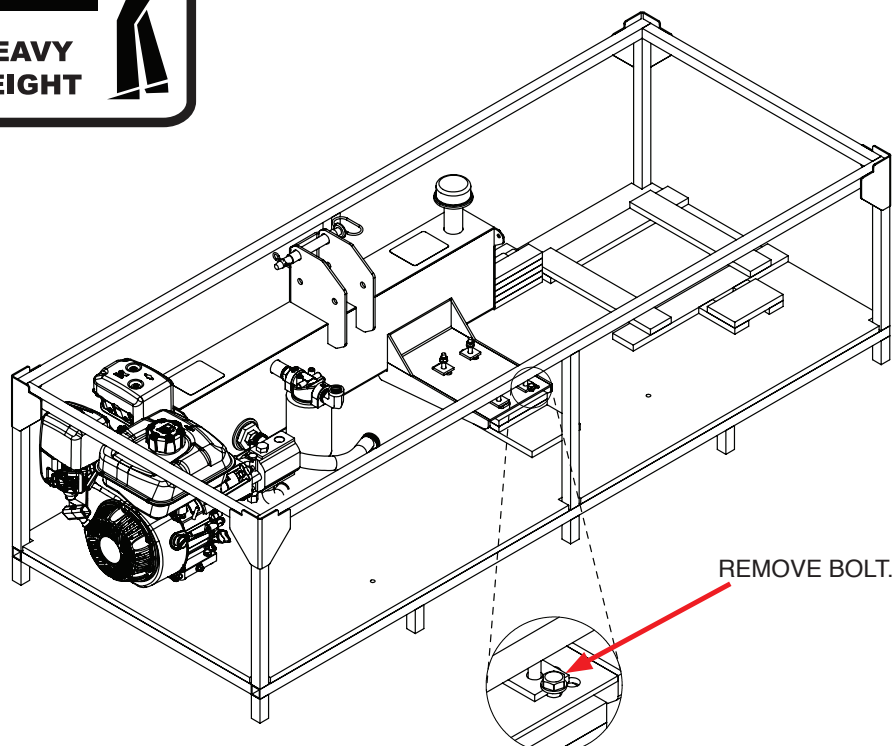

BW MACHINERY® 1 - Unpacking the Container

Step 1.5

Use a 13mm wrench / socket wrench to remove the two hex bolts that secure the Honda engine to the crate bottom (right).

Step 1.6

Remove tank and engine assembly from crate.

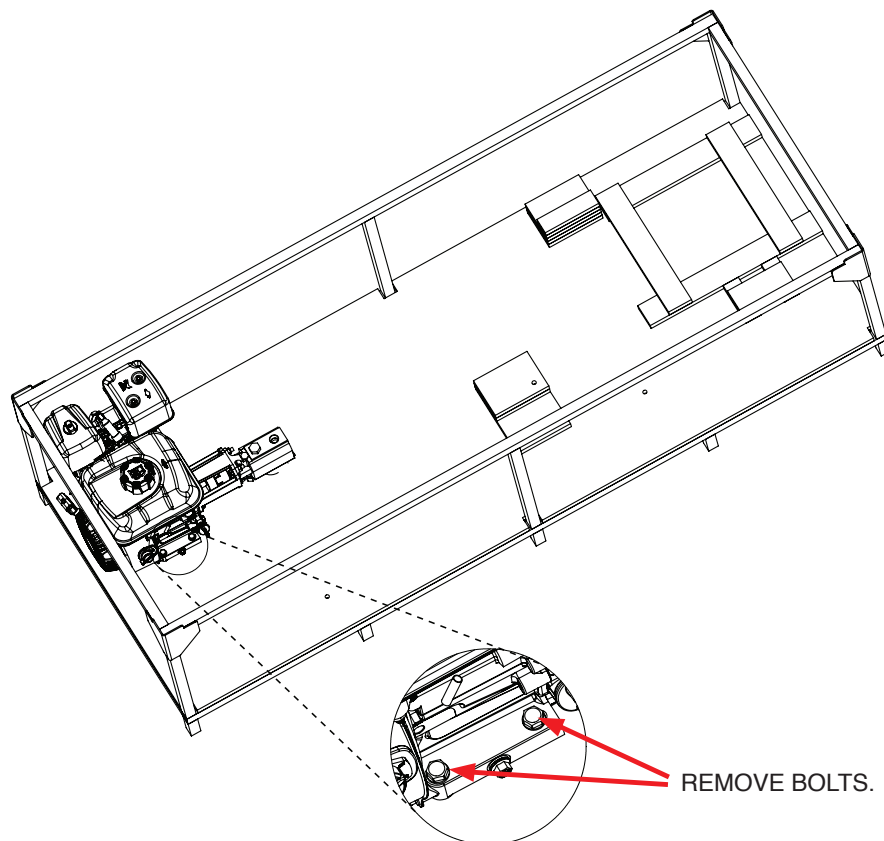

2 - Tank and Engine Assembly **BW**MACHINERY®

Step 2.1

Remove **engine bolts (5)** from tank.

Step 2.2

Place **engine (2)** on tank.

Step 2.3

Secure **engine on tank (1)** in 4 places with hex bolt **(5)**, flat washer **(6)** and locking hex nut **(7)**.

Step 2.4

Attach **suction line tube (3)** to pump.

Step 2.5

Fasten the **suction line tube** to the pump assembly with **hose clamp (4)**.

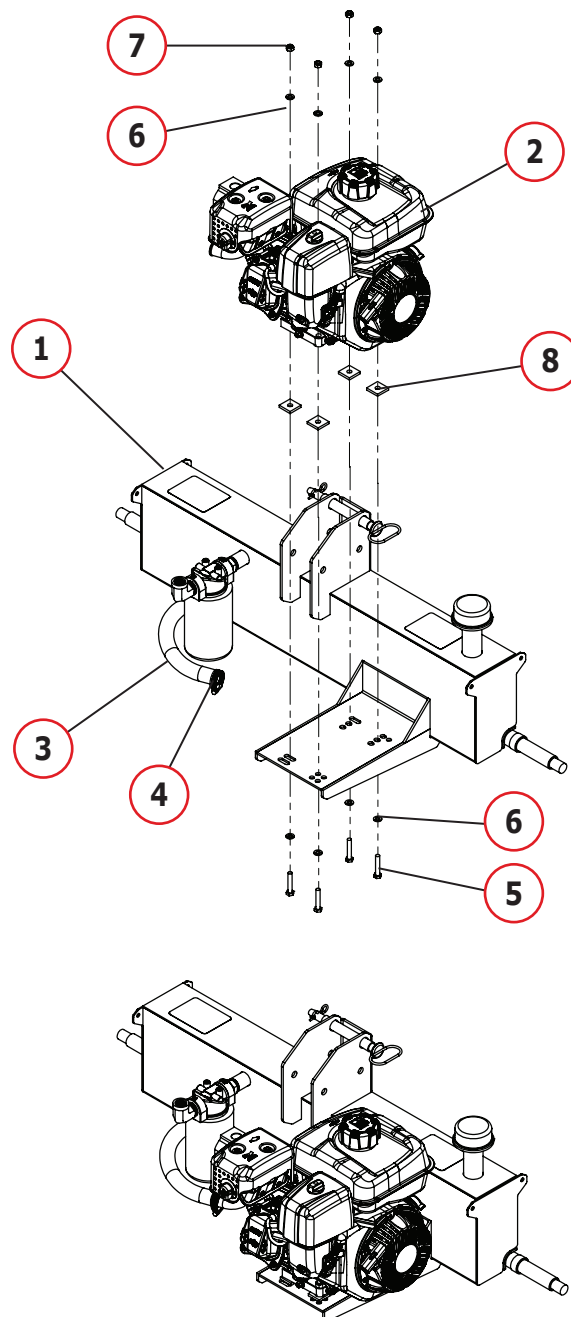

No.	Part No.	Description	Qty.
1	BWMLS101	Tank assembly (30 ton)	1
	BWMLS192	Tank assembly (35/40 ton)	
2		Honda GP200 or GX200 (30 ton)	1
		Honda GX270 (35 ton)	
		Honda GX390 (40 ton)	
3	BWMLS117	Suction line tube	1
4	BWMLS118	Hose clamp, 15/16" to 1-1/4"	2

No.	Part No.	Description	Qty.
5	BWMLS119	Hex bolt, M8 x 45, G8.8	4
6	BWMLS120	Flat washer, M8	8
7	BWMLS121	Locking hex nut, M8 x 1.25, G8.8	4
8	BWMLS122	Rubber engine damper	4

BW MACHINERY® 3 - Tank and Wheel Assembly

Step 3.1

Remove disposable spindle covers and wheel bearing covers.

Step 3.2

Slide **wheel/tyre assembly (2)** on to the spindle with valve stem of tyre facing outwards.

Step 3.3

Install the **flat washer (3)** onto the spindle.

Step 3.4

Thread the slotted **castle nut (4)** onto the spindle. The slotted nut should be attached with a 28mm socket tight enough to eliminate the free-play of the wheel assembly and not tighter. Make sure the wheels can freely rotate. The castle nut needs to be oriented to allow for the installation of the **cotter pin (5)**.

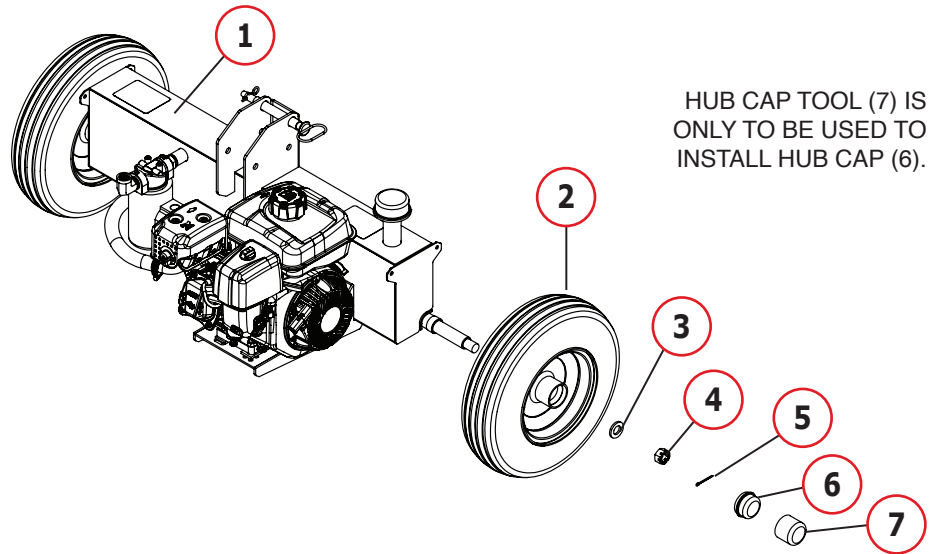

Step 3.5

Install the **cotter pin** through the **castle nut** and spindle. Bend pin ends around spindle to secure its position.

Step 3.6

Install the **hub cap (6)** using the **hub cap tool (7)**. Gently tap on the hub cap tool with a hammer to drive the hub cap into place.

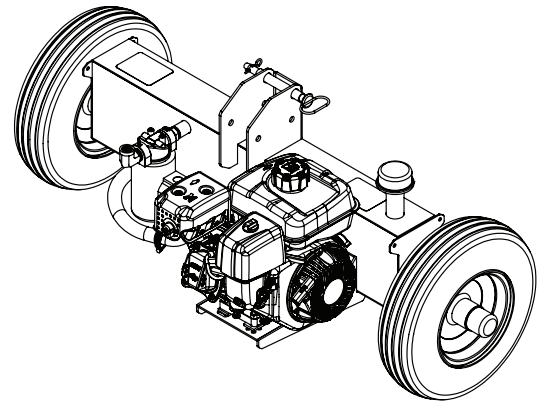

Step 3.7

Repeat Steps 1 - 6 to install the second wheel.

No.	Part No.	Description	Qty.
1	BWMLS128	Tank & engine assembly (30 ton)	1
	BWMLS195	Tank & engine assembly (35/40 ton)	
2	BWMLS104	Wheel/tyre assembly, 4.80 x 8"	2
3	BWMLS123	Flat washer, 3/4"	2
4	BWMLS124	Castle nut, 3/16" 16, clear zinc	2

No.	Part No.	Description	Qty.
5	BWMLS125	Cotter pin, 1/8" x 1-1/2"	2
6	BWMLS126	Hub cap	2
7	BWMLS127	Hub cap tool	1

4 - Tank and Tongue Assembly **BW**MACHINERY®

Step 4.1

Attach the **tongue and stand assembly (2)** to the tank and engine assembly **(1)** with hex bolt **(3)**, flat washer **(4)**, lock washer **(5)** and hex nut **(6)** in two places. Tighten securely using 19mm socket wrench.

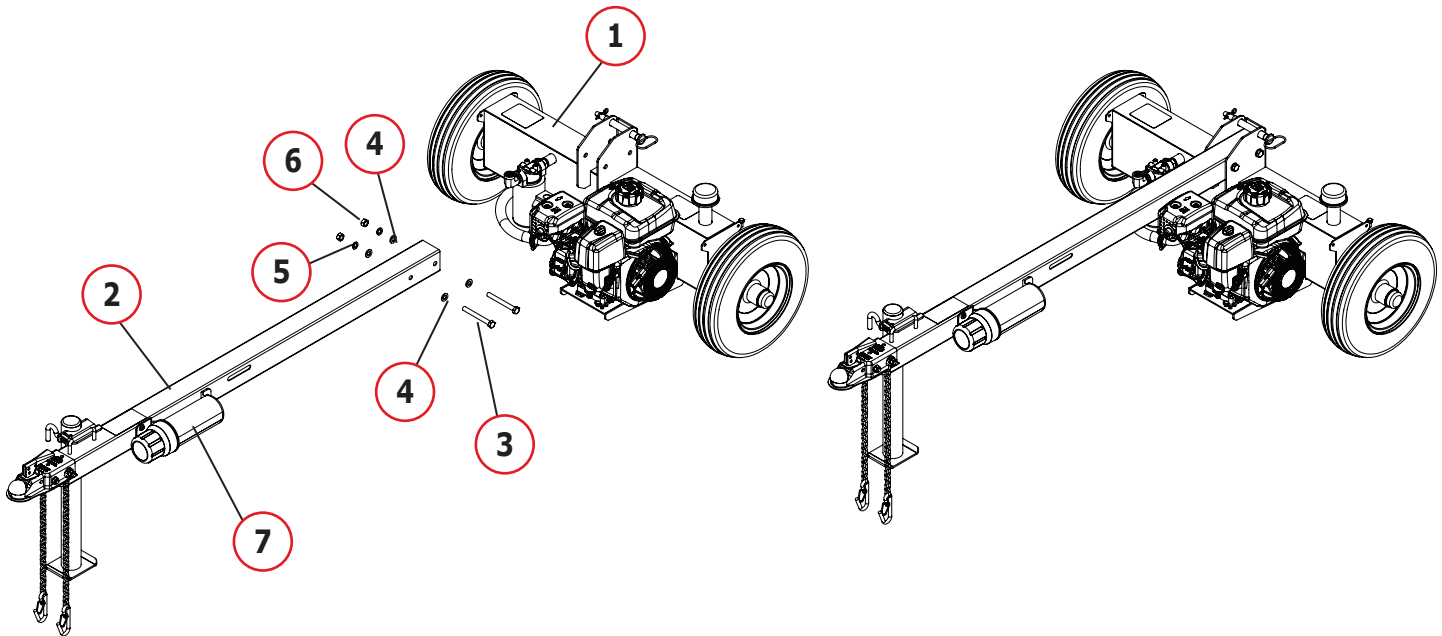

No.	Part No.	Description	Qty.
1	BWMLS128	Tank & engine assembly (30 ton)	1
	BWMLS195	Tank & engine assembly (35/40 ton)	1
2	BWMLS102	Tongue & stand assembly (30 ton)	1
	BWMLS193	Tongue & stand assembly (35/40 ton)	1
3	BWMLS129	Hex bolt M12 x 1.75 x 110mm, G8.8	2
4	BWMLS130	Flat washer, M12	4

No.	Part No.	Description	Qty.
5	BWMLS131	Lock washer, M12	2
6	BWMLS132	Hex nut, M12 x 1.75, G8.8	2
7	BWMLS133	Manual canister	1

BW MACHINERY® 5 - Beam Bracket Assembly

Step 5.1

Attach the **beam lock bracket (2)** to the **beam and cylinder assembly (1)** with hex bolt **(4)**, flat washer **(5)**, lock washer **(6)** and hex nut **(7)** in two places. Tighten securely using 19mm socket wrench.

Step 5.2

Attach the **pivot bracket (3)** to the **beam and cylinder assembly (1)** using the four bottom holes with hex bolt **(4)**, flat washer **(5)**, lock washer **(6)** and hex nut **(7)** in four places. Tighten securely using 19mm socket wrench.

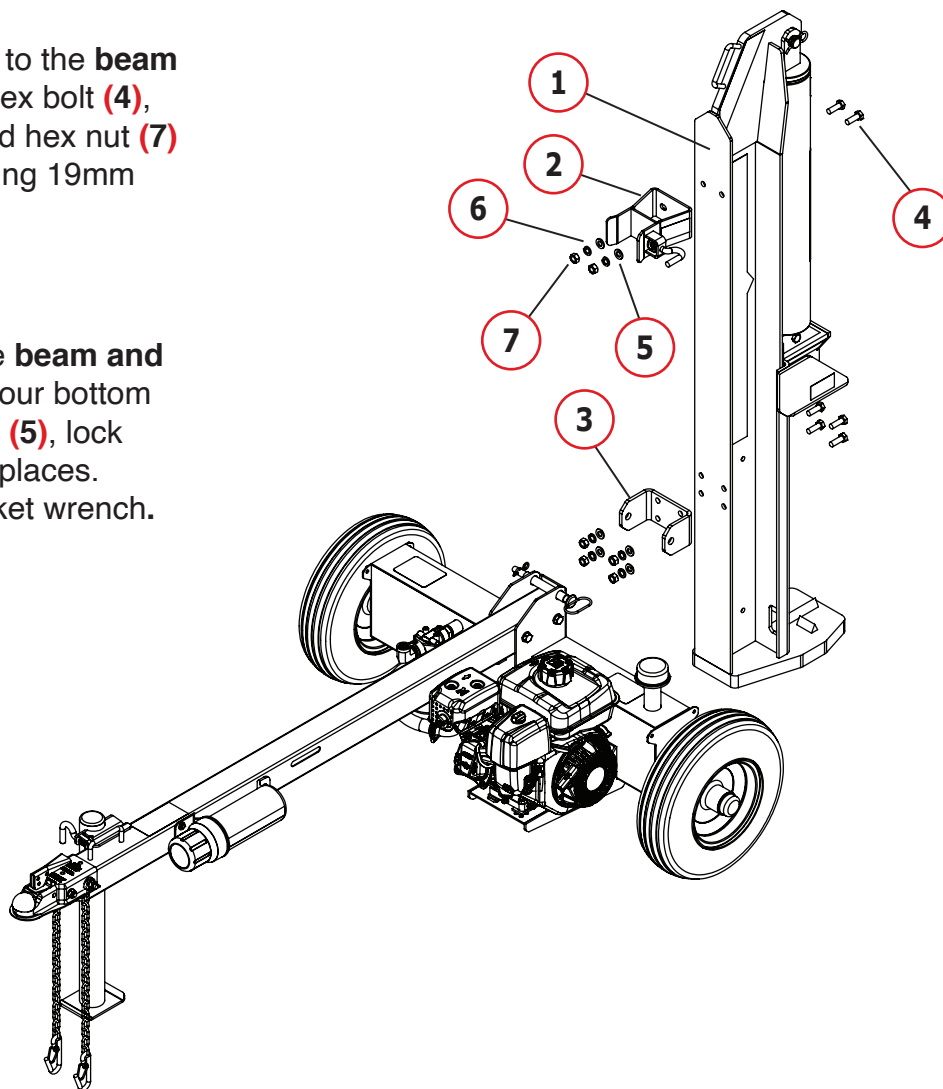

No.	Part No.	Description	Qty.
1	BWMLS103	Beam & cylinder assembly (30 ton)	1
	BWMLS194	Beam & cylinder assembly (35/40 ton)	1
2	BWMLS134	Beam lock bracket	1
3	BWMLS135	Beam pivot bracket	1
4	BWMLS129	Hex bolt, M12 x 1.75 x 35mm, G8.8	6

No.	Part No.	Description	Qty.
5	BWMLS130	Flat washer, M12	6
6	BWMLS131	Lock washer, M12	6
7	BWMLS132	Hex nut, M12 x 1.75, G8.8	6

6 - Beam and Tank Assembly **BW**MACHINERY®

Step 6.1

Rotate the jack stand attached to the side of the tongue assembly downwards into position by releasing the pin and then securing the release pin.

Step 6.2

Remove the **retaining clip (2)** and **hitch pin (1)** from the assembled unit (below).

Step 6.3

Slowly back the assembled unit up to the beam and cylinder assembly. Align the tongue bracket of the assembled unit to the pivot bracket of the beam assembly.

Step 6.4

Once the brackets are aligned, install the **hitch pin (1)** through the brackets then install the **retaining clip (2)** into the hitch pin.

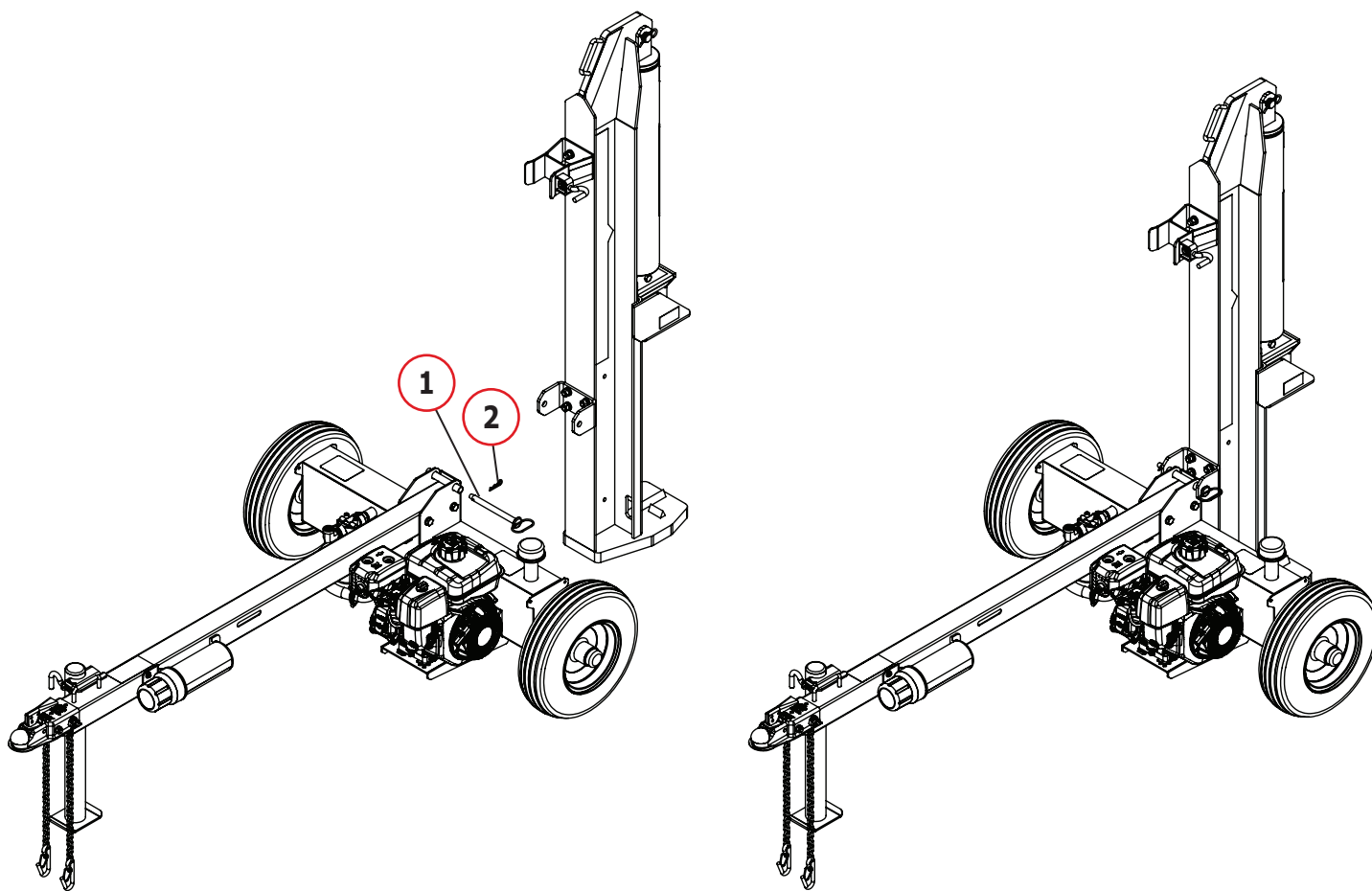

No.	Part No.	Description	Qty.
1	BWMLS136	Hitch pin 5/8" x 6-1/4"	1

No.	Part No.	Description	Qty.
2	BWMLS137	R-clip, 1/8". Fits 1/2" to 3/4"	1

BW MACHINERY® 7 - Hydraulic Line Connection

Step 7.1

Hold **hydraulic hose (1)** and **(2)** above the level of the hydraulic tank to prevent fluid leakage and remove the end caps.

Step 7.2

Apply Teflon tape or pipe sealant on to the hose fitting threads. Install the ends of the two **hydraulic hoses (1)** and **(2)** to the **valve** (as shown in detail drawing below). Securely tighten the fitting connections using 22mm and 24mm wrench.

Step 7.3

Remove tank cap and install the vent cap.



CAUTION

On pre-filled log splitters, hold hoses above the level of the hydraulic tank before removing end caps.

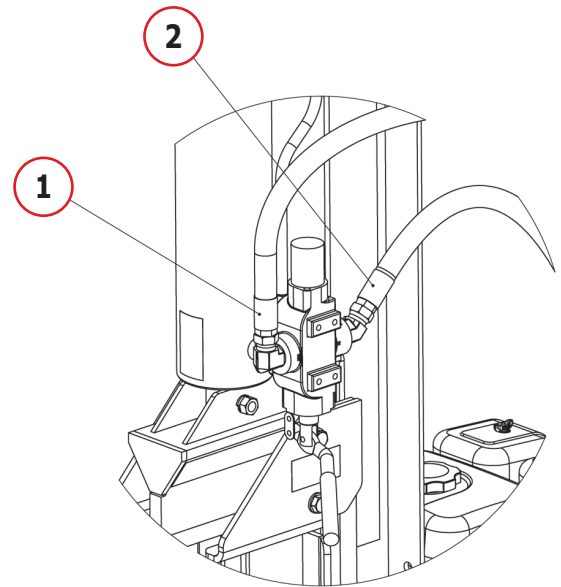
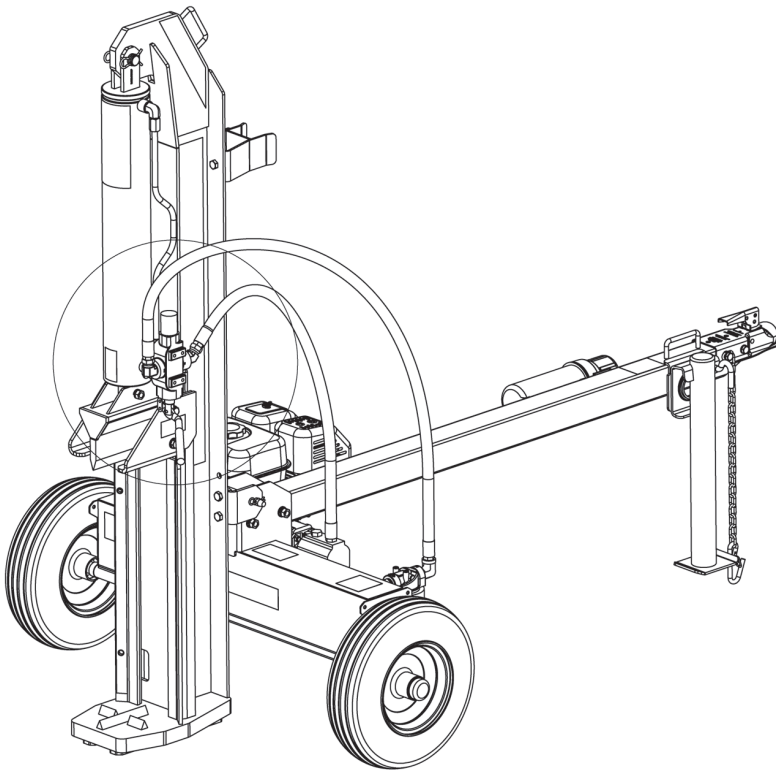

No.	Part No.	Description	Qty.
1	BWMLS138	Hydraulic hose, 1/2" x 56"	1

No.	Part No.	Description	Qty.
2	BWMLS139	Hydraulic hose, 1/2" x 38", high pressure	1

8 - Log Catcher Installation **BW**MACHINERY®

Step 8.1

Rotate beam and cylinder assembly down from upright position and lock in place with the release pin.

Step 8.2

Install the **log catcher assembly (1)** with hex bolts **(2)**, flat washer **(3)**, lock washer **(4)**, hex nut **(5)** and button screw **(6)** in two places. Tighten hex nuts securely with a 17mm socket wrench and tighten button screws with 6mm hex key wrench.

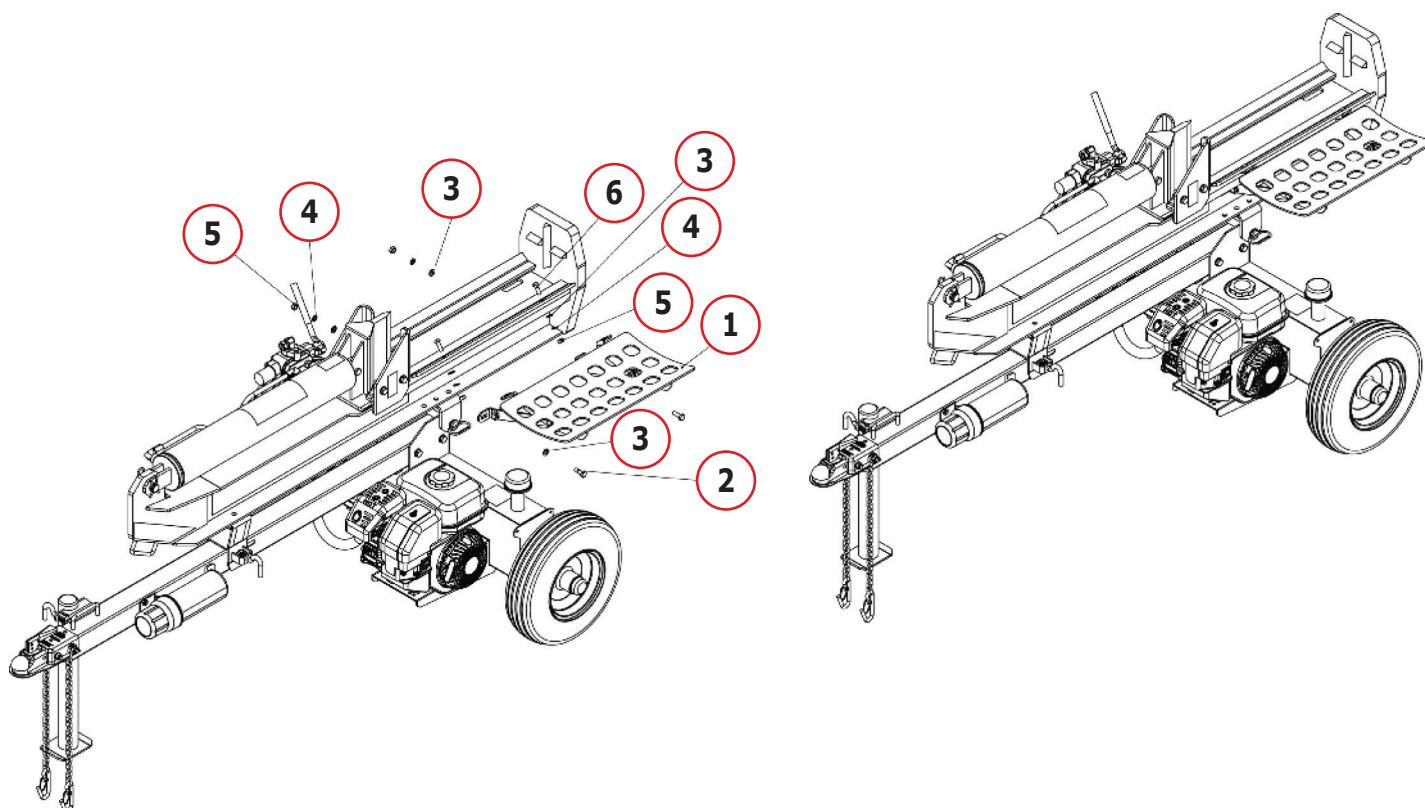

No.	Part No.	Description	Qty.
1	BWMLS107	Log catcher assembly	1
2	BWMLS112	Hex bolt M10 x 1.5 x 30mm, G8.8	2
3	BWMLS115	Flat washer, M10	4

No.	Part No.	Description	Qty.
4	BWMLS113	Lock washer, M10	4
5	BWMLS114	Hex nut, M10 x 1.5, G8.8	4
6	BWMLS140	Button screw, M10 x 1.5 x 30mm, G8.8	2

9 - Final Installation Check

Step 9.1

Check tightness of all fittings, nuts and bolts prior to filling the log splitter with fluids.

BW MACHINERY® **Operating Instructions**

WARNING: Read and understand the complete operation manual before assembling or using this product! Failure to comprehend and comply with warnings, cautions and instructions for assembly and operation could result in serious injury or death.



DO NOT permit children to operate this equipment at any time. **DO NOT** permit others that have not read and understood the complete operation manual to operate this equipment. Operation of power equipment can be dangerous. It is the sole responsibility of the operator to understand the assembly and safe operation of this product.

CAUTION: Oil must be added to the hydraulic reservoir and the engine before starting or operation.



Step 1

Please add approximately 15/20 litres of hydraulic fluid. The remaining hydraulic fluid will be added after the cylinder is cycled. AW46 hydraulic oil is recommended. Use only clean oil and take care to prevent dirt from entering the hydraulic reservoir.

ENGINE OIL RECOMMENDATIONS

Use 4 stroke automotive detergent oil. SAE 10W30 is recommended for general use. Refer to the SAE Viscosity Grades chart in your engine owner's manual for average temperature ranges. The engine oil capacity is 600ml for the Honda GX200 (30 ton), 1.1lts for the Honda GX270 (35 ton) and 1.1lts for the Honda GX390 (40 ton). Always check oil level before starting the engine and keep level full.

Step 2

After the hydraulic reservoir and the engine crankcase are filled with oil, start the engine. The hydraulic pump is self-priming. With the engine running, move the hydraulic valve lever toward the foot plate. This will cause the cylinder to extend and expel air. When the cylinder is fully extended, retract it. Repeat this procedure several times. An erratic movement of the cylinder indicates that there is still air in the system. Add about 3 to 6 litres of hydraulic fluid. Approximately 19 litres will register just above the top fill line on the dip stick. The total capacity of the entire hydraulic system is 30 litres, with 19 litres of hydraulic fluid minimum to operate.

NOTE: If the tank is overfilled it will expel oil from the breather cap when the cylinder is retracted. Cycle the cylinder again until it has a constant speed which indicates that all air has been expelled.

STARTING INSTRUCTIONS

NOTE: Refer to the engine owner's manual for complete information on starting, maintenance and troubleshooting.

1. Move the fuel valve lever to the **ON** position.
2. To start a cold engine, move the choke lever to the **CLOSE** position. To restart a warm engine, leave the choke lever in the **OPEN** position.
3. Move the throttle lever away from the **SLOW** position, about 1/3 of the way toward the **FAST** position.
4. Turn the engine switch to the **ON** position.
5. Pull the starter grip until you feel resistance, then pull briskly. Return the starter grip gently.
6. If the choke lever has been moved to the **CLOSE** position to start the engine, gradually move it to the **OPEN** position as the engine warms up.
7. To stop the engine in an emergency, simply turn the engine switch to the **OFF** position. Under normal conditions, move the throttle lever to the **SLOW** position and then turn the engine switch to the **OFF** position. Then turn the fuel valve lever to the **OFF** position.

For further information on starting and stopping the engine, refer to your engine owner's manual.



CAUTION: Turn fuel shut off valve to the **OFF** position before towing to avoid flooding the engine.

NOTE: The engines maximum speed is factory preset at 3600 RPM as the no load speed. The throttle should be set at the maximum speed for wood splitting to reach the horsepower required for the pump.



WARNING: Review safety information related to operation of the log splitter on pages 3-6 of this manual. Make sure that you have the recommended personal protective equipment described on page 3.

Store manuals in the manual cannister attached to the tongue of the log splitter or file in a safe place for future reference.

NOTE: For operation in wooded areas, obtain a spark arrestor for the exhaust system. See the engine operating and maintenance manual and check with your authorised service centre. See also **FIRE PREVENTION** on page 8 of this manual.

IMPORTANT: To extend the life of the hydraulic cylinder avoid bottoming out the wedge plate to the foot piece. To conform with industry safety recommendations the wedge stops 1/2" from the end of the stroke.

BW MACHINERY® Operating Instructions

1. Set up the log splitter in a clear, level area and block the wheels. Make sure that the suction port on the tank is always on the lower side of the log splitter.
2. For horizontal operation place a log on the beam against the foot plate. Make sure the log is securely on the foot plate and against the beam. To split wood in the vertical position, release the pin on the beam latch located on the front end of the beam. Carefully tilt the beam up until the foot plate is sitting squarely on the ground and the log splitter is stable. Place the log on the foot plate against the beam. When the beam is returned to the horizontal position make sure the beam latch is securely locked down.
3. With the engine running, depress the valve handle so that the cylinder will drive the wedge into the log. Extend the cylinder until the log splits or to the end of its stroke. If the log has not completely split after the cylinder has reached the end of its extension, retract the cylinder.

IMPORTANT: Leaving the valve in the **ACTUATE** position at the end of the stroke may damage the pump. Always use extra care when splitting logs with unsquare ends.

FOR HORIZONTAL OPERATION

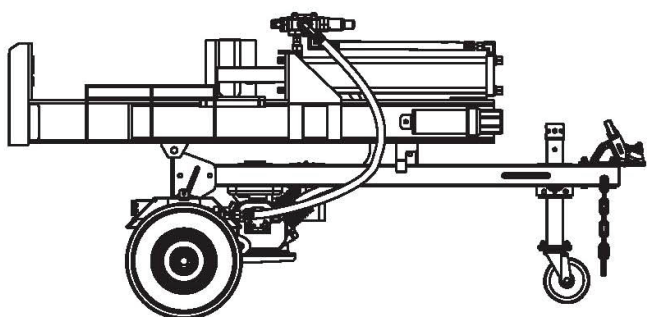

FOR VERTICAL OPERATION

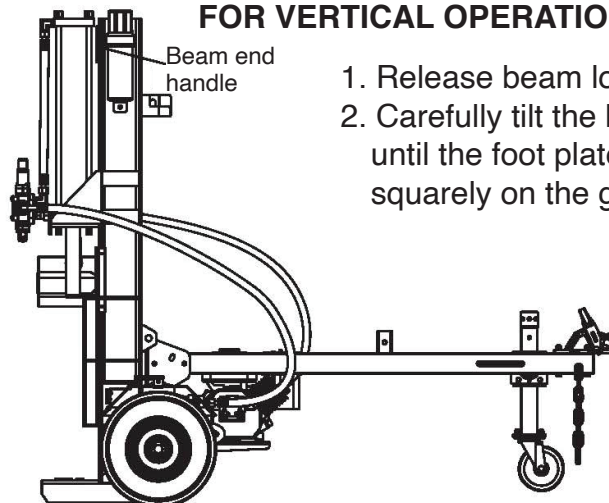

1. Release beam lock pin
2. Carefully tilt the beam up until the foot plate is sitting squarely on the ground

MAINTENANCE

1. Consult the operating and maintenance instructions of the engine manufacturer for engine care and maintenance.
2. Always check the oil level of the hydraulic reservoir before operation. Operating the log splitter without an adequate oil supply will cause severe damage to the pump.
3. Change the oil filter after the first 25 hours of operation. There after change the oil filter every 100 hours or seasonally, whichever comes first.
4. To drain the hydraulic oil, loosen the clamp on the hose coming from the fitting on the bottom of the tank. It is located just to the right of the oil filter.
5. If the wedge becomes dull or nicked, it can be removed and sharpened. Remove the bolt that connects the wedge to the cylinder. The hose from the valve may need to be removed. Carefully lift the cylinder to allow the wedge to slide forward. The wedge can now be lifted off and sharpened.
6. Clean the breather cap after 25 hours of operation. Clean it more often when operated in dusty conditions. To clean, remove the breather cap from the tank and flush with kerosene or liquid detergent to remove the dirt.
7. See **REPAIRS AND MAINTENANCE** on page 7 of this manual.
8. All replacement parts must meet manufacturer's specifications.

Operating Instructions **BW**MACHINERY®

TOWING

This log splitter is equipped with pneumatic tyres, a Class I coupler (2" diameter ball required) and safety chains. Before towing, the safety chains must be secured to the hitch or bumper of the vehicle. Local regulations should be checked regarding licensing, lights, towing, etc. Turn fuel shut off valve on the engine to the **OFF** position prior to towing. Failure to do so may result in flooding the engine. Do not exceed 70km/h when towing this log splitter. See also **TOWING SAFETY** on page 8 of this manual.

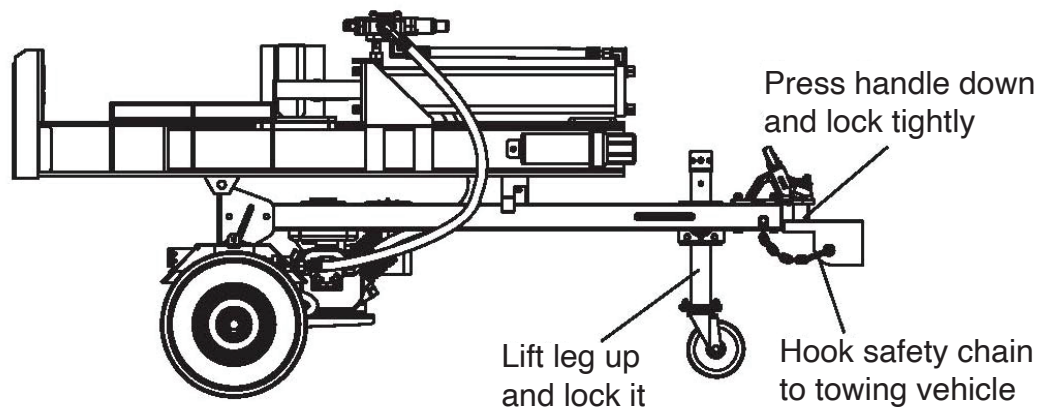

WARNING

TOWING HAZARDS

- ❑ **SERIOUS INJURY** or **DEATH** can occur if towing safety rules are not followed.
- ❑ **REVIEW** towing safety warnings in your towing vehicle manual.
- ❑ **DRIVE SAFELY.** Be aware of the added length of the log splitter.
- ❑ **NEVER** ride or transport cargo on the log splitter.
- ❑ **TURN OFF** the vehicle before leaving the log splitter unattended.
- ❑ Choose a level surface to operate the log splitter.
- ❑ Block the log splitter wheels to prevent unintended movement.
- ❑ **NEVER** tow or operated this log splitter while under the influence of alcohol, drugs or medication.

HOW TO SPLIT A LOG WITH A SLANTED SURFACE

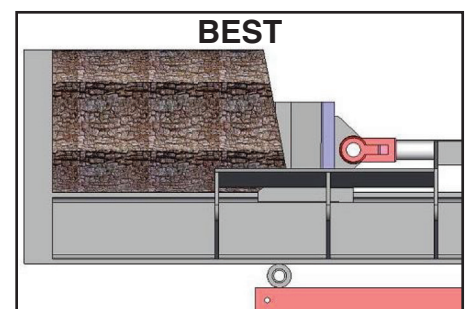
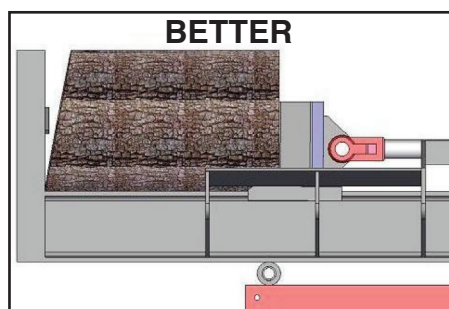
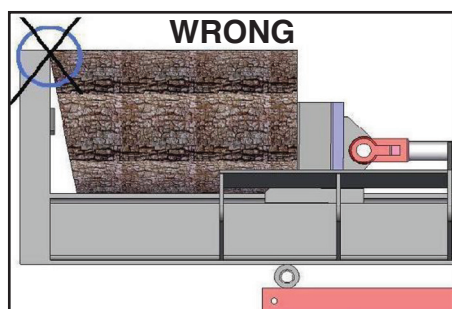

BW MACHINERY® Pump & Engine Parts

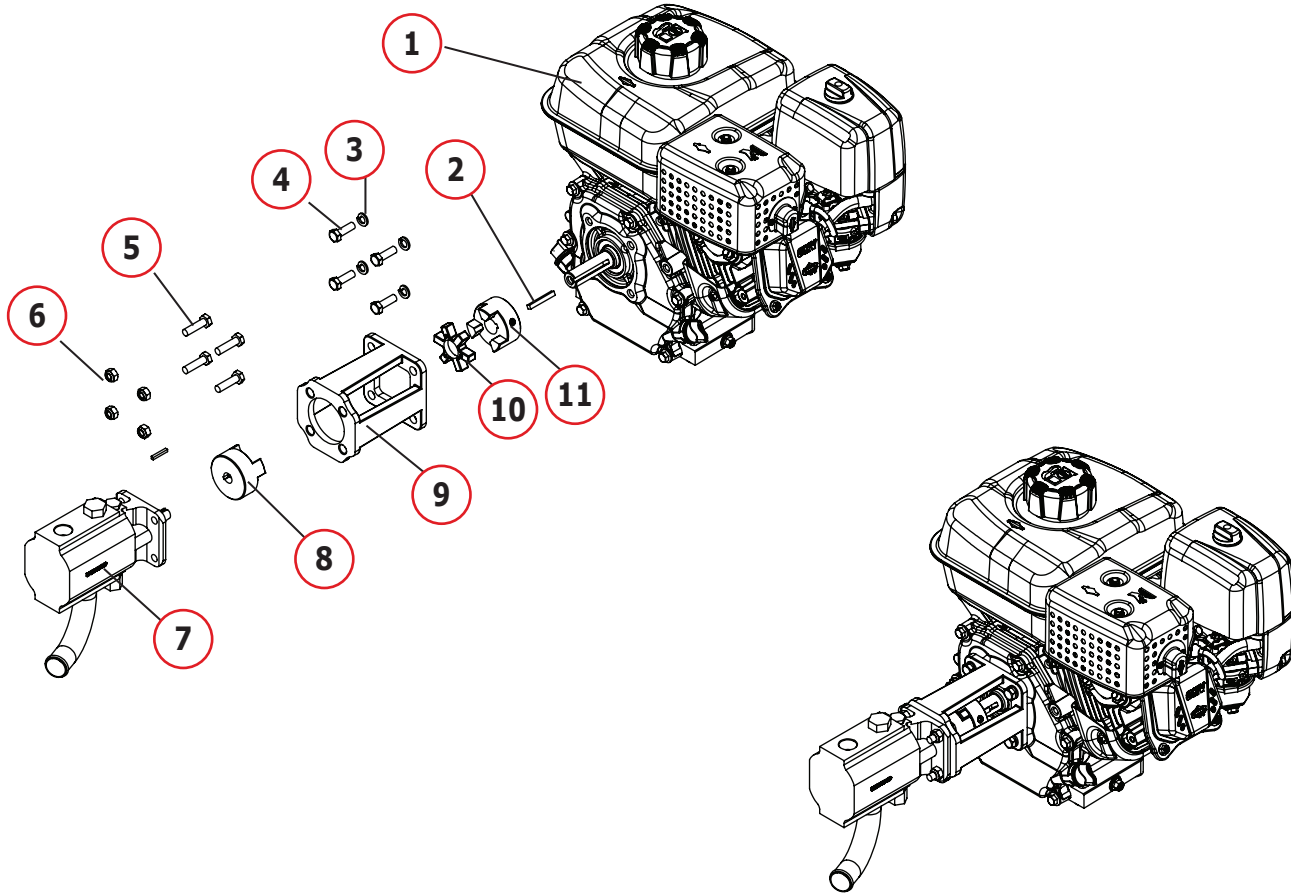

No.	Part No.	Description	Qty.
1		Honda GP200 or GX200 (30 ton) Honda GX270 (35 ton) Honda GX390 (40 ton)	1
2	BWMLS141	Bar, key stock SQ 3/16" x 1-1/2"	1
3	BWMLS142	Lock washer, M8	4
4	BWMLS143	Hex bolt, M8 x 10 x 25mm, G8.8	4
5	BWMLS144	Hex bolt, M8 x 1.25 x 30mm, G8.8	4
6	BWMLS121	Locking hex nut, M8 x 1.25, G8.8	4

No.	Part No.	Description	Qty.
7	BWMLS145	Pump, 13 GPM (30 ton)	1
	BWMLS196	Pump, 17.5 GPM (35/40 ton)	1
8	BWMLS146	Jaw coupler assembly, 1/2" bore, L090	1
9	BWMLS147	Pump mount, 92mm BC	1
10	BWMLS148	Jaw spider coupler, L090	1
11	BWMLS149	Jaw coupler assembly, 3/4" bore	1

Tank Parts **BW**MACHINERY®

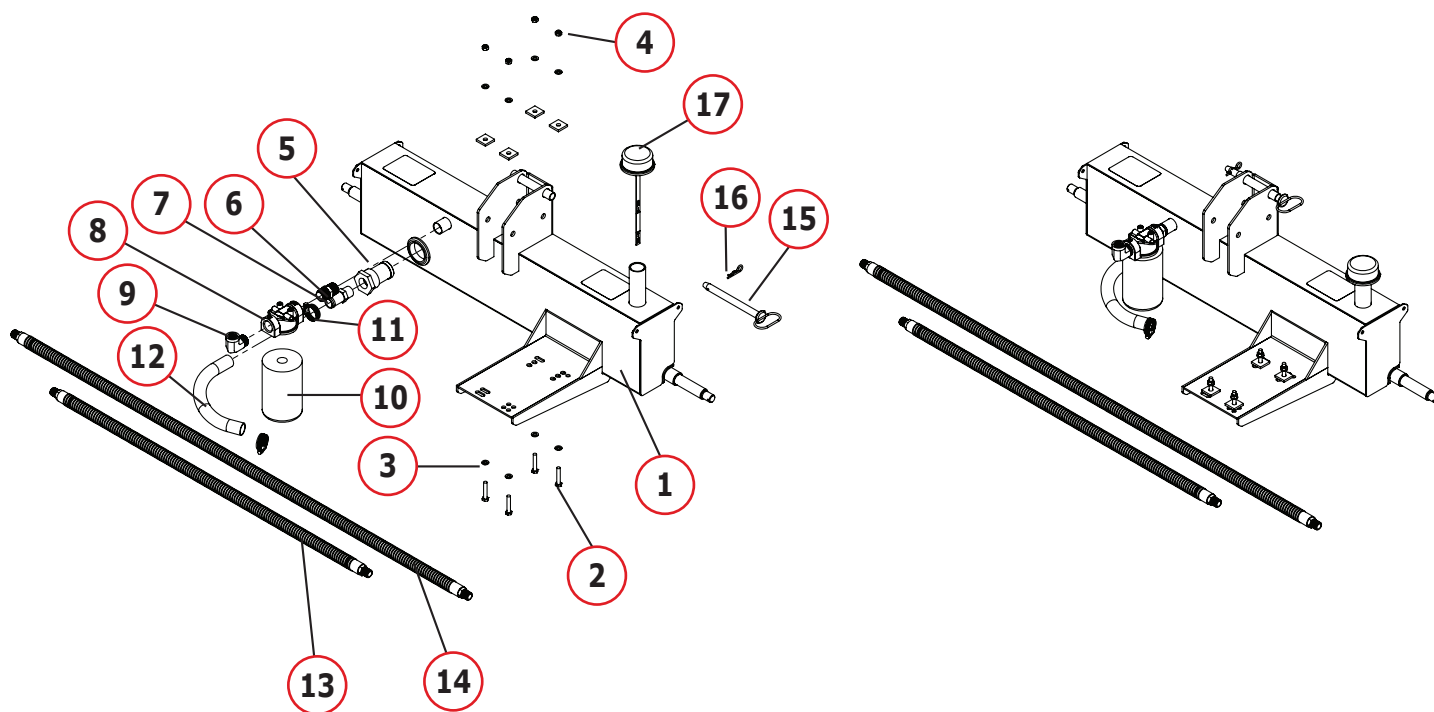

No.	Part No.	Description	Qty.
1	BWMLS150 BWMLS197	Tank with decals (30 ton) Tank with decals (35/40 ton)	1
2	BWMLS119	Hex bolt, M8 x 1.25 x 45mm, G8.8	4
3	BWMLS120	Flat washer, M8	8
4	BWMLS121	Locking hex nut, M8 x 1.25, G8.8	4
5	BWMLS151	Suction Filter	1
6	BWMLS152	Fitting, 3/4 NPT to 1" tube	1
7	BWMLS153	Fitting, M 3/4 NPT, M 3/4 NPT	1
8	BWMLS154	Filter base, 3/4 NPT, 1-12 UNF	1
9	BWMLS155	Elbow, M 3/4 NPT, F 1/2 NPT	1

No.	Part No.	Description	Qty.
10	BWMLS156	Hydraulic oil filter	1
11	BWMLS157	Hose clamp, 15/16" to 1-1/4"	2
12	BWMLS158	Suction line tube, wire reinforced	1
13	BWMLS139	Hydraulic hose, 1/2" x 38", high pressure	1
14	BWMLS138	Hydraulic hose, 1/2" x 56"	1
15	BWMLS136	Hitch pin, 5/8" x 6-1/4"	1
16	BWMLS137	R-Clip, 1/8", 1/2" to 3/4"	1
17	BWMLS159	Vent cap assembly	1

BW MACHINERY[®] Tongue Parts

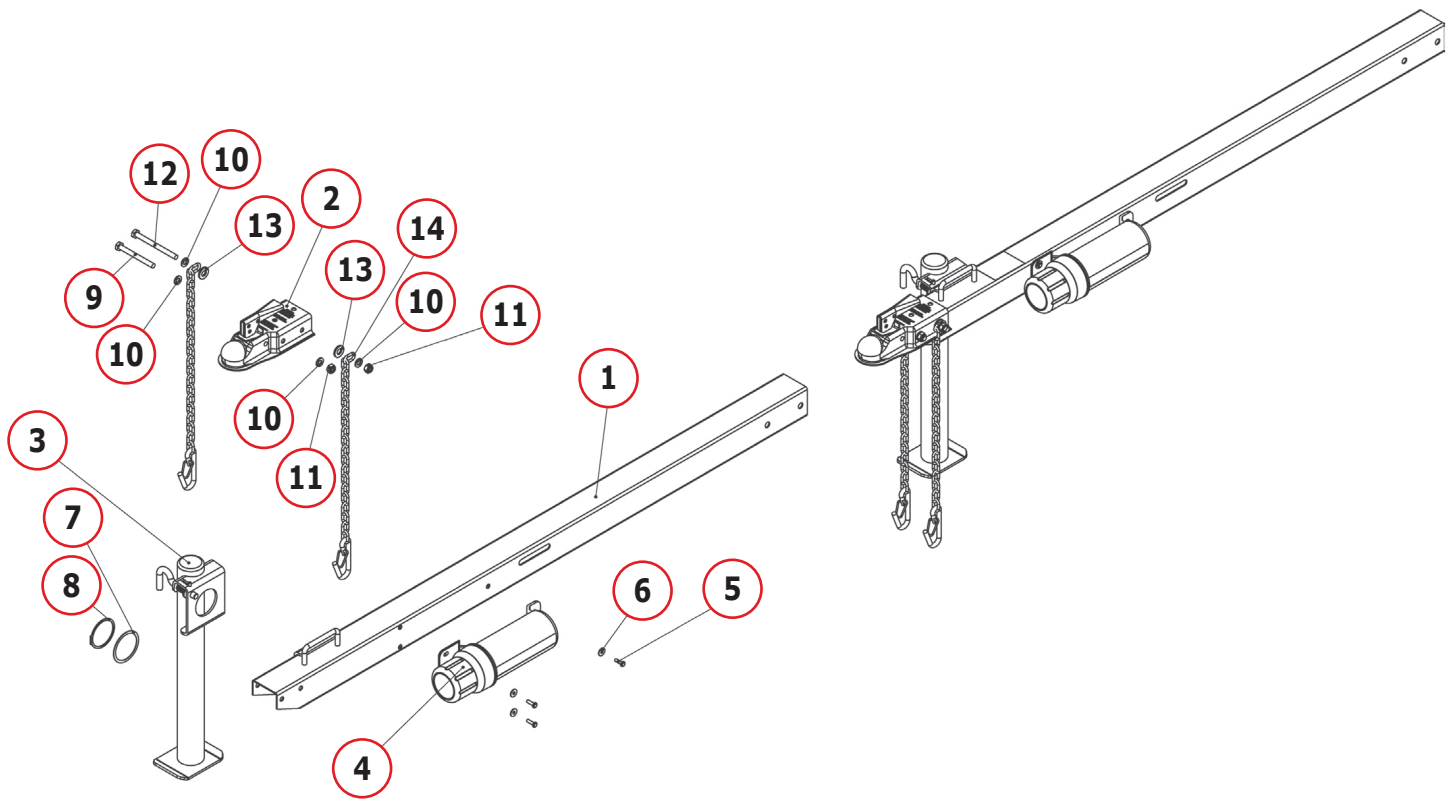

No.	Part No.	Description	Qty.
1	BWMLS160	Tongue	1
2	BWMLS161	Ball coupler assembly, 2"	1
3	BWMLS162	Tongue stand	1
4	BWMLS133	Manual canister	1
5	BWMLS163	Hex bolt, M6 x 1.0 x 20mm, G8.8	3
6	BWMLS164	Fender washer, M6	3
7	BWMLS165	Shim, OD 75mm, ID 64mm x 1mm	1

No.	Part No.	Description	Qty.
8	BWMLS166	Retaining ring, external, 63mm shaft	1
9	BWMLS167	Hex bolt, M10 x 1.5 x 100mm, G8.8	1
10	BWMLS115	Flat washer, M10	4
11	BWMLS168	Locking hex nut, M10 x 1.5, G8.8	2
12	BWMLS169	Hex bolt, M10 x 1.5 x 120mm, G8.8	1
13	BWMLS170	Flat washer, 1/2"	2
14	BWMLS171	Safety chain	2

Beam Parts **BW**MACHINERY®

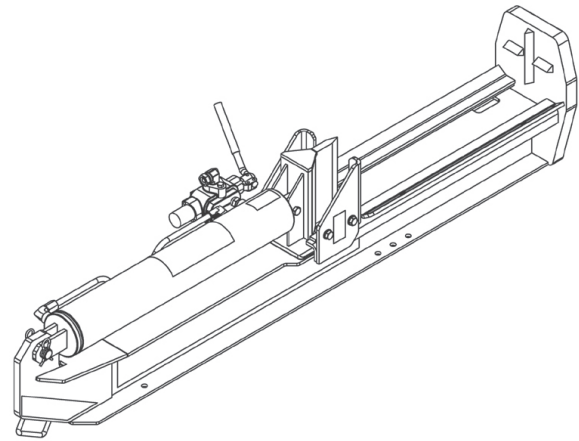
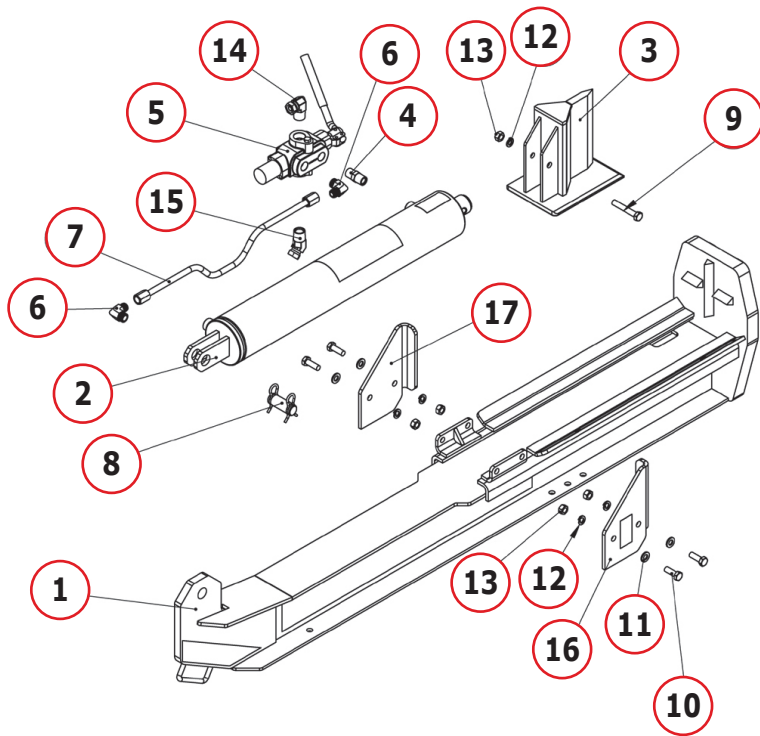

No.	Part No.	Description	Qty.
1	BWMLS172	Beam (30 ton)	1
	BWMLS198	Beam (35/40 ton)	1
2	BWMLS173	Cylinder assembly, 4-1/2", F 1/2 NPT (30 ton)	1
	BWMLS199	Cylinder assembly, 5", F 1/2 NPT (35/40 ton)	1
3	BWMLS174	Wedge, 8.5" (30 ton)	1
	BWMLS200	Wedge, 9" (35/40 ton)	1
4	BWMLS175	Nipple, 1/2 NPT, 1/2 NPT	1
5	BWMLS176	Valve, adj. detent, 3000 PSI (30 ton)	1
	BWMLS201	Valve, adj. detent, 4000 PSI (35/40 ton)	1
6	BWMLS177	Elbow, 1/2 NPT, 1/2 flare tube	2
7	BWMLS178	Tube, 1/2 OD, flared, 3/4-16" nuts	1
8	BWMLS179	Clevis pin assy, 1" OD, w/clips (30 ton)	1
	BWMLS202	Clevis pin assy, 1" OD, w/clips (35/40 ton)	1

No.	Part No.	Description	Qty.
9	BWMLS180	Hex bolt, M12 x 1.75 x 75mm, G8.8	1
10	BWMLS129	Hex bolt, M12 x 1.75 x 35mm, G8.8	4
11	BWMLS130	Flat washer, M12	4
12	BWMLS131	Lock washer, M12	5
13	BWMLS132	Hex nut, M12X1.75, G8.8	5
14	BWMLS181	Elbow, M 3/4 NPT to F1/2 NPT	1
15	BWMLS182	Fitting, 45°, M 3/4 NPT to F1/2 NPT	1
16	BWMLS183	Stripper, RT	1
17	BWMLS184	Stripper, LT	1

BW MACHINERY® Warranty

IMPORTANT NOTICE

We, the manufacturer, reserves the right to change the product and/or specifications in this manual without notifications.

The manual is for information references only and the pictures and drawings depicted herein are for references only.

WARRANTY AND REPAIR SERVICE

Please call our customer service team on **1300 454 585** for any warranty issues or repairs.

Record the information below for future reference.

Model No: _____ Date of purchase: _____

Serial No: _____ Place of purchase: _____

Specifications

Part No.	BWMLS30	BWMLS35	BWMLS40
Maximum splitting force	30 Tons	35 Tons	40 Tons
Engine	Honda GP200 or GX200	Honda GX270	Honda GX390
Maximum log length	25" (635mm)	25" (635mm)	25" (635mm)
Cycle time, down & back	10.5 seconds	11.5 seconds	11.5 seconds
Cylinder	4-1/2" dia x 24" stroke	5" dia x 24" stroke	5" dia x 24" stroke
Pump, two stage	13 GPM	17.5 GPM	17.5 GPM
Wedge, heat treated steel	8.5" high	9" high	9" high
Beam	8.5" foot plate	9" foot plate	9" foot plate
Hydraulic capacity	32 litres max.	32 litres max.	32 litres max.
Shipping weight	260kg	306kg	306kg
Valve	Auto return with adjustable detent		
Wheels	D.O.T. approved 16" O.D road tyres		
Coupler	2" ball with safety chains		
Warranty	2 Years, limited		

¹ Tonnage and cycle times may vary dependent on mechanical and environmental conditions.

² As rated by engine manufacturer

³ Minimum operational capacity is 19 litres of hydraulic fluid



Customer Hotline
1300 454 585.